

**COSEL**|科索 PBA300F-48 **PDF**

**COSEL**

**深圳创唯电子有限公司**

*<http://www.cosef.net>*



# PBA, PBW-series

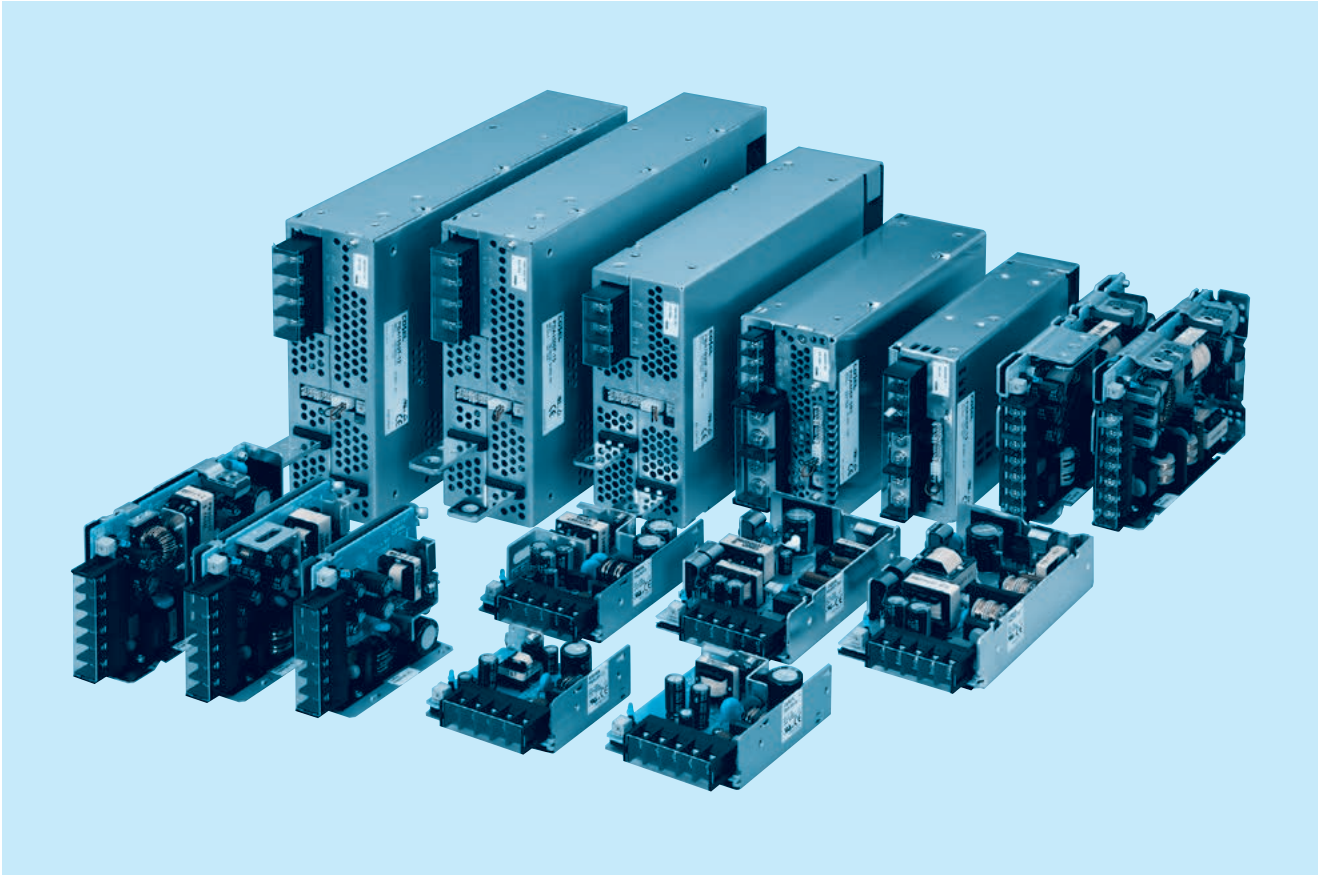

## Feature

- Small-size & light weight
- Harmonic attenuator (Complies with IEC61000-3-2) : except PBA1500T
- Universal input (AC85 - 264V) : PBA1500T(AC170 - 264V 3  $\phi$ )
- Efficiency increased with synchronous rectification technology (PBA50F - 150F)
- Variety of option (PBA10F - 150F, PBW15F - 50F)
- Parallel operation and Parallel redundancy operation (PBA300F - 1500F, PBA1500T)
- Fan alarm, Remote ON/OFF and other functions (PBA300F - 1500F, PBA1500T)

## Safety agency approvals

- UL60950-1, C-UL(CSA60950-1), EN60950-1, EN50178
- UL508 (PBA10F - 150F, -24, with cover)
- Complies with DEN-AN

## EMI

- Complies with FCC-B, CISPR22-B, EN55011-B, EN55022-B, VCCI-B

## 5-year warranty (refer to Instruction Manual)

## CE marking

- Low Voltage Directive
- RoHS Directive

## EMS Compliance : EN61204-3, EN61000-6-2

- EN61000-4-2
- EN61000-4-3
- EN61000-4-4
- EN61000-4-5
- EN61000-4-6
- EN61000-4-8
- EN61000-4-11

# PBA10F

PB A 10 F -□ -□  
 ① ② ③ ④ ⑤ ⑥

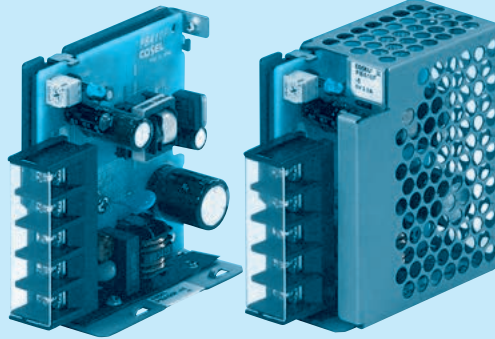
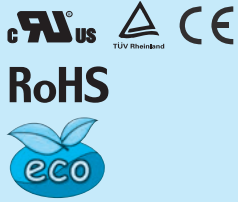

Example recommended EMI/EMC filter  
**NAC-06-472**



High voltage pulse noise type : NAP series  
 Low leakage current type : NAM series  
 \*A higher current rating EMI/EMC filter may be recommended in view of the other devices that could be connected in parallel with the power supply.

- ① Series name
- ② Single output
- ③ Output wattage
- ④ Universal input
- ⑤ Output voltage
- ⑥ Optional \*5
- C : with Coating
- G : Low leakage current
- E : Low leakage current and EMI class A
- T : Vertical terminal block
- J1 : VH (J.S.T.) connector type
- N : with Cover (UL508 is acquired)
- N1 : with DIN rail and Cover
- V : Output voltage setting potentiometer externally

Cover is optional

\*Make sure necessary tests will be carried out on your end equipment with the power supply installed in accordance with any required EMC/EMI regulations.

MODEL	PBA10F-5	PBA10F-12	PBA10F-24
MAX OUTPUT WATTAGE[W]	10	10.8	12
DC OUTPUT	5V 2A	12V 0.9A	24V 0.5A

## SPECIFICATIONS

	MODEL	PBA10F-5	PBA10F-12	PBA10F-24	
INPUT	VOLTAGE[V]	AC85 - 264 1 φ or DC110 - 370 (AC50 or DC70 Please refer to the instruction manual 1.1 Input voltage *3)			
	CURRENT[A]	ACIN 100V	0.30typ (Io=100%)		
		ACIN 200V	0.20typ (Io=100%)		
	FREQUENCY[Hz]	50/60 (47 - 440) or DC			
	EFFICIENCY[%]	ACIN 100V	74typ	76typ	77typ
		ACIN 200V	74typ	76typ	77typ
	INRUSH CURRENT[A]	ACIN 100V	15typ (Io=100%)		
	ACIN 200V	30typ (Io=100%)			
LEAKAGE CURRENT[ma]	0.15/0.30max (ACIN 100V/240V 60Hz, Io=100%, According to IEC60950-1.DENAN)				
OUTPUT	VOLTAGE[V]	5	12	24	
	CURRENT[A]	2	0.9	0.5	
	LINE REGULATION[mV] *6	20max	48max	96max	
	LOAD REGULATION[mV] *6	40max	100max	150max	
	RIPPLE[mVp-p]	0 to +50°C *1	80max	120max	120max
		-10 - 0°C *1	140max	160max	160max
	RIPPLE NOISE[mVp-p]	0 to +50°C *1	120max	150max	150max
		-10 - 0°C *1	160max	180max	180max
	TEMPERATURE REGULATION[mV]	0 to +50°C	50max	120max	240max
		-10 to +50°C	60max	150max	290max
	DRIFT[mV] *2	20max	48max	96max	
	START-UP TIME[ms]	200typ (ACIN 100V, Io=100%) *Start-up time is 700ms typ for less than 1minute of applying input again from turning off the input voltage.			
	HOLD-UP TIME[ms]	20typ (ACIN 100V, Io=100%)			
OUTPUT VOLTAGE ADJUSTMENT RANGE[V]	4.50 - 5.50	10.0 - 13.2	19.2 - 27.0		
OUTPUT VOLTAGE SETTING[V]	5.00 - 5.15	12.00 - 12.48	24.00 - 24.96		
OVERCURRENT PROTECTION	Works over 105% of rated current and recovers automatically				
OVERVOLTAGE PROTECTION[V]	5.75 - 7.00	15.0 - 18.0	30.0 - 37.0		
OPERATING INDICATION	LED (Green)				
REMOTE ON/OFF	None				
ISOLATION	INPUT-OUTPUT	AC3,000V 1minute, Cutoff current = 10mA, DC500V 50MΩmin (At Room Temperature)			
	INPUT-FG	AC2,000V 1minute, Cutoff current = 10mA, DC500V 50MΩmin (At Room Temperature)			
	OUTPUT-FG	AC500V 1minute, Cutoff current = 25mA, DC500V 50MΩmin (At Room Temperature)			
ENVIRONMENT	OPERATING TEMP.,HUMID.AND ALTITUDE	-10 to +71°C (Refer to "Derating"), 20 - 90%RH (Non condensing) 3,000m (10,000feet) max			
	STORAGE TEMP.,HUMID.AND ALTITUDE	-20 to +75°C, 20 - 90%RH (Non condensing) 9,000m (30,000feet) max			
	VIBRATION	10 - 55Hz, 19.6m/s <sup>2</sup> (2G), 3minutes period, 60minutes each along X, Y and Z axis			
	IMPACT	196.1m/s <sup>2</sup> (20G), 11ms, once each X, Y and Z axis			
SAFETY AND NOISE REGULATIONS	AGENCY APPROVALS (At only AC input)	UL60950-1, C-UL(CSA60950-1), EN60950-1, EN50178 Complies with DEN-AN			
	CONDUCTED NOISE	Complies with FCC Part15 classB, VCCI-B, CISPR22-B, EN55011-B, EN55022-B			
	HARMONIC ATTENUATOR	Complies with IEC61000-3-2 (Not built-in to active filter *4) *7			
OTHERS	CASE SIZE/WEIGHT	31 × 78 × 68mm [1.22 × 3.07 × 2.68 inches] (without terminal block) (W×H×D) / 150g max (with cover : 180g max)			
	COOLING METHOD	Convection			

\*1 Measured by 20MHz oscilloscope or Ripple-Noise meter(equivalent to KEISOKU-GIKEN :RM101).  
 \*2 Drift is the change in DC output for an eight hour period after a half-hour warm-up at 25°C.  
 \*3 Derating is required.  
 \*4 When two or more units are used,they may not comply with the harmonic attenuator. Please contact us for details.

\*5 Please contact us about safety approvals for the model with option.  
 \*6 Please contact us about dynamic load and input response.  
 \*7 Please contact us about class C.  
 \* Parallel operation with other model is not possible.  
 \* Derating is required when operated with cover.  
 \* A sound may occur from power supply at peak loading.

Block diagram

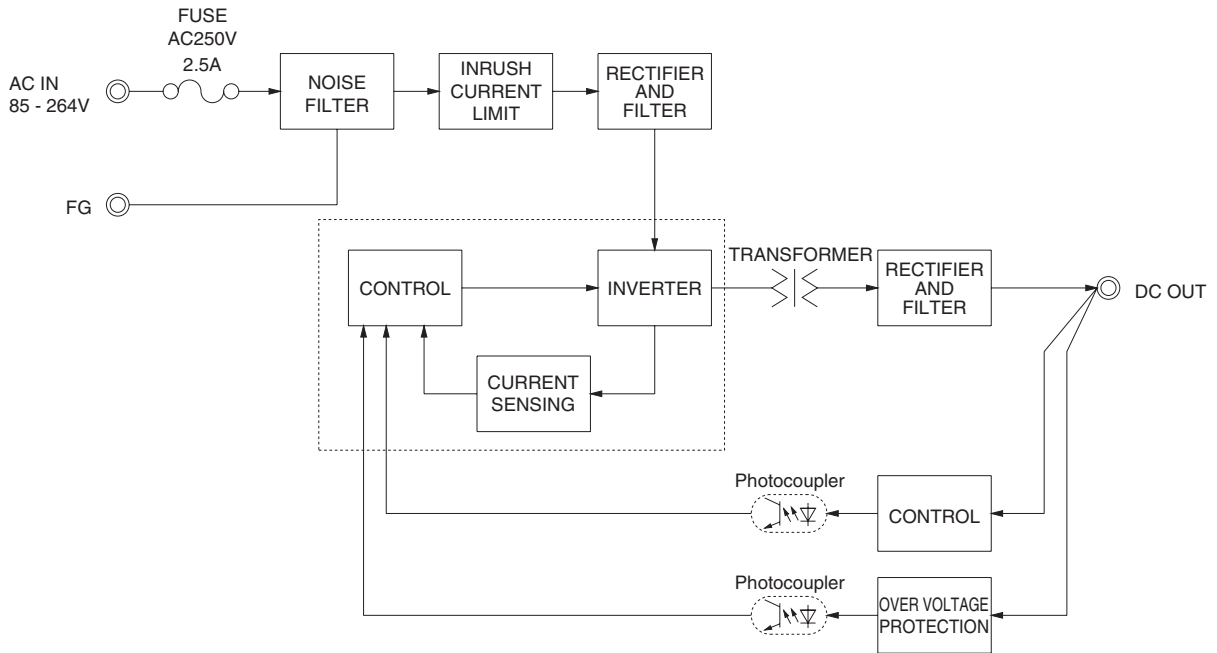

External view

※ External size of option T,J1,N1 and V is different from standard model and refer to 7 Option of instruction manual for details.

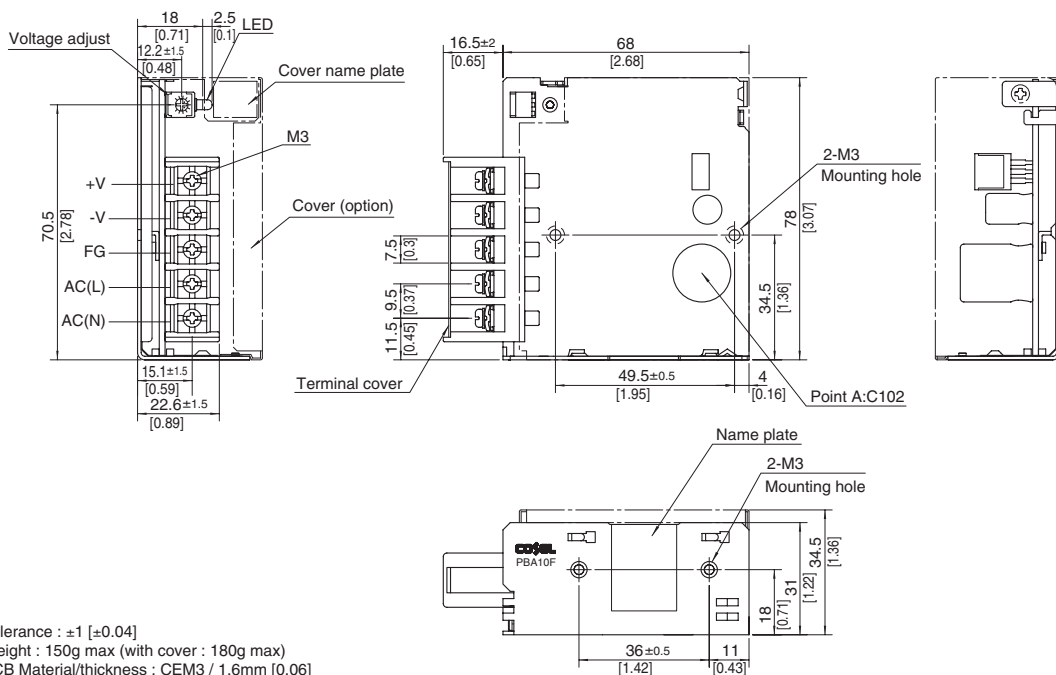

- ※ Tolerance : ±1 [±0.04]
- ※ Weight : 150g max (with cover : 180g max)
- ※ PCB Material/thickness : CEM3 / 1.6mm [0.06]
- ※ Chassis material : Electric galvanizing steel board
- ※ Dimensions in mm, [ ] = inches
- ※ Mounting torque : 0.6N • m(6.3kgf • cm)max
- ※ Screw tightening torque : M3 0.8N • m(8.5kgf • cm)max
- ※ Please connect safety ground to the unit in 2-M3 holes.

# PBA15F

PB A 15 F -□ -□  
 ① ② ③ ④ ⑤ ⑥

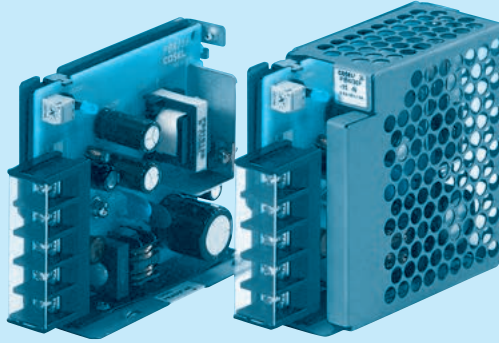
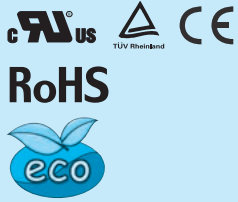

Example recommended EMI/EMC filter  
**NAC-06-472**



High voltage pulse noise type : NAP series  
 Low leakage current type : NAM series  
 \*A higher current rating EMI/EMC filter may be recommended in view of the other devices that could be connected in parallel with the power supply.

- ① Series name
- ② Single output
- ③ Output wattage
- ④ Universal input
- ⑤ Output voltage
- ⑥ Optional \*5
- C : with Coating
- G : Low leakage current
- E : Low leakage current and EMI class A
- T : Vertical terminal block
- J1 : VH (J.S.T.) connector type
- N : with Cover (UL508 is acquired [5V, 12V, 24V])
- N1 : with DIN rail and Cover
- V : Output voltage setting potentiometer externally

Cover is optional

\*Make sure necessary tests will be carried out on your end equipment with the power supply installed in accordance with any required EMC/EMI regulations.

MODEL	PBA15F-3R3	PBA15F-5	PBA15F-9	PBA15F-12	PBA15F-15	PBA15F-24	PBA15F-48
MAX OUTPUT WATTAGE[W]	9.9	15	15.3	15.6	15	16.8	16.8
DC OUTPUT	3.3V 3A	5V 3A	9V 1.7A	12V 1.3A	15V 1A	24V 0.7A	48V 0.35A

## SPECIFICATIONS

	MODEL	PBA15F-3R3	PBA15F-5	PBA15F-9	PBA15F-12	PBA15F-15	PBA15F-24	PBA15F-48	
INPUT	VOLTAGE[V]	AC85 - 264 1 φ or DC110 - 370 (AC50 or DC70 Please refer to the instruction manual 1.1 Input voltage *3)							
	CURRENT[A]	ACIN 100V	0.30typ (Io=100%)	0.4typ (Io=100%)					
		ACIN 200V	0.15typ (Io=100%)	0.2typ (Io=100%)					
	FREQUENCY[Hz]	50/60 (47 - 440) or DC							
	EFFICIENCY[%]	ACIN 100V	68typ	74typ	75typ	75typ	77typ	75typ	75typ
		ACIN 200V	68typ	75typ	77typ	78typ	80typ	78typ	78typ
	INRUSH CURRENT[A]	ACIN 100V	15typ (Io=100%) (At cold start)						
ACIN 200V		30typ (Io=100%) (At cold start)							
LEAKAGE CURRENT[ma]	0.15/0.30max (ACIN 100V/240V 60Hz, Io=100%, According to IEC60950-1.DENAN)								
OUTPUT	VOLTAGE[V]	3.3	5	9	12	15	24	48	
	CURRENT[A]	3	3	1.7	1.3	1	0.7	0.35	
	LINE REGULATION[mV] *6	20max	20max	36max	48max	60max	96max	192max	
	LOAD REGULATION[mV] *6	40max	40max	100max	100max	120max	150max	240max	
	RIPPLE[mVp-p]	0 to +50°C *1	80max	80max	120max	120max	120max	120max	150max
		-10 - 0°C *1	140max	140max	160max	160max	160max	160max	200max
	RIPPLE NOISE[mVp-p]	0 to +50°C *1	120max	120max	150max	150max	150max	150max	250max
		-10 - 0°C *1	160max	160max	180max	180max	180max	180max	300max
	TEMPERATURE REGULATION[mV]	0 to +50°C	50max	50max	90max	120max	150max	240max	480max
		-10 to +50°C	60max	60max	120max	150max	180max	290max	600max
	DRIFT[mV] *2	20max	20max	36max	48max	60max	96max	192max	
	START-UP TIME[ms]	200typ(ACIN 100V, Io=100%) *Start-up time is 700ms typ for less than 1minute of applying input again from turning off the input voltage.							
HOLD-UP TIME[ms]	20typ (ACIN 100V, Io=100%)								
OUTPUT VOLTAGE ADJUSTMENT RANGE[V]	2.85 - 3.60	4.50 - 5.50	7.50 - 10.0	10.0 - 13.2	13.2 - 18.0	19.2 - 27.0	39.0 - 53.0		
OUTPUT VOLTAGE SETTING[V]	3.30 - 3.40	5.00 - 5.15	9.00 - 9.36	12.00 - 12.48	15.00 - 15.60	24.00 - 24.96	48.00 - 49.92		
PROTECTION CIRCUIT AND OTHERS	OVERCURRENT PROTECTION	Works over 105% of rated current and recovers automatically							
	OVERVOLTAGE PROTECTION[V]	4.00 - 5.25	5.75 - 7.00	11.5 - 14.0	15.0 - 18.0	20.0 - 25.0	30.0 - 37.0	58.0 - 65.0	
	OPERATING INDICATION	LED (Green)							
	REMOTE ON/OFF	None							
ISOLATION	INPUT-OUTPUT	AC3,000V 1minute, Cutoff current = 10mA, DC500V 50MΩmin (At Room Temperature)							
	INPUT-FG	AC2,000V 1minute, Cutoff current = 10mA, DC500V 50MΩmin (At Room Temperature)							
	OUTPUT-FG	AC500V 1minute, Cutoff current = 25mA, DC500V 50MΩmin (At Room Temperature)							
ENVIRONMENT	OPERATING TEMP.,HUMID.AND ALTITUDE	-10 to +71°C (Refer to "Derating"), 20 - 90%RH (Non condensing) 3,000m (10,000feet) max							
	STORAGE TEMP.,HUMID.AND ALTITUDE	-20 to +75°C, 20 - 90%RH (Non condensing) 9,000m (30,000feet) max							
	VIBRATION	10 - 55Hz, 19.6m/s <sup>2</sup> (2G), 3minutes period, 60minutes each along X, Y and Z axis							
	IMPACT	196.1m/s <sup>2</sup> (20G), 11ms, once each X, Y and Z axis							
SAFETY AND NOISE REGULATIONS	AGENCY APPROVALS (At only AC input)	UL60950-1, C-UL(CSA60950-1), EN60950-1, EN50178 Complies with DEN-AN							
	CONDUCTED NOISE	Complies with FCC Part15 classB, VCCI-B, CISPR22-B, EN55011-B, EN55022-B							
	HARMONIC ATTENUATOR	Complies with IEC61000-3-2 (Not built-in to active filter *4) *7							
OTHERS	CASE SIZE/WEIGHT	31 × 78 × 85mm [1.22 × 3.07 × 3.35 inches] (without terminal block) (W×H×D) / 200g max (with cover : 235g max)							
	COOLING METHOD	Convection							

\*1 Measured by 20MHz oscilloscope or Ripple-Noise meter(equivalent to KEISOKU-GIKEN :RM101).  
 \*2 Drift is the change in DC output for an eight hour period after a half-hour warm-up at 25°C.  
 \*3 Derating is required.  
 \*4 When two or more units are used,they may not comply with the harmonic attenuator. Please contact us for details.

\*5 Please contact us about safety approvals for the model with option.  
 \*6 Please contact us about dynamic load and input response.  
 \*7 Please contact us about class C.  
 \* Parallel operation with other model is not possible.  
 \* Derating is required when operated with cover.  
 \* A sound may occur from power supply at peak loading.

Block diagram

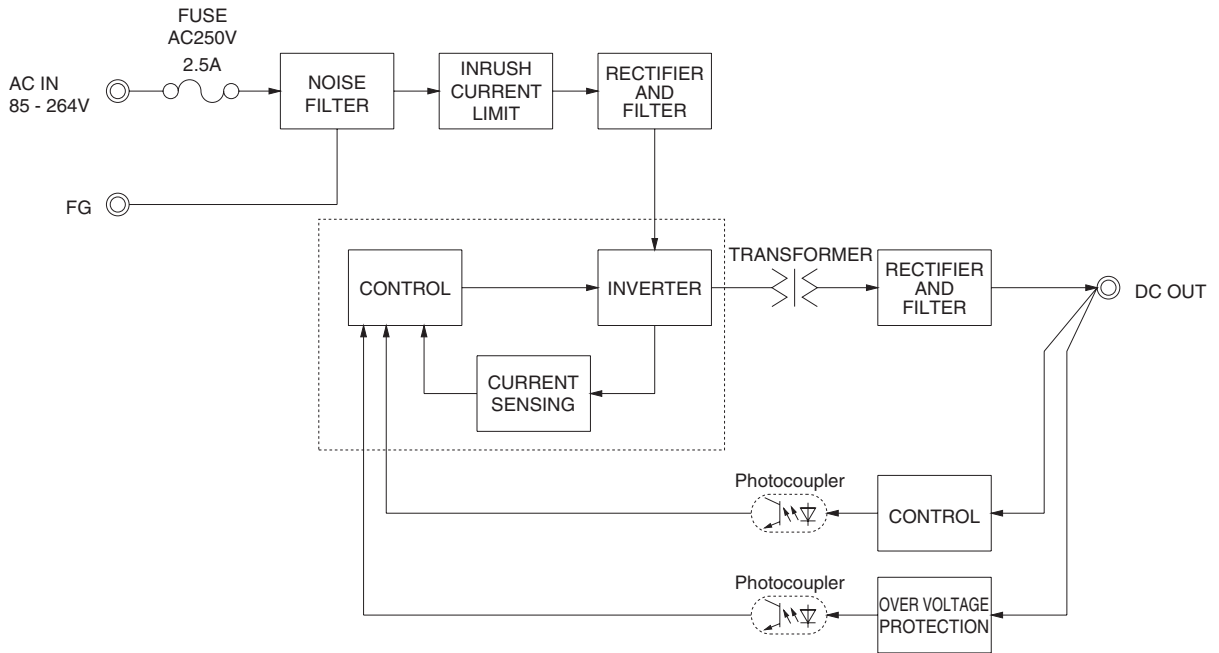

External view

※ External size of option T,J1,N1 and V is different from standard model and refer to 7 Option of instruction manual for details.

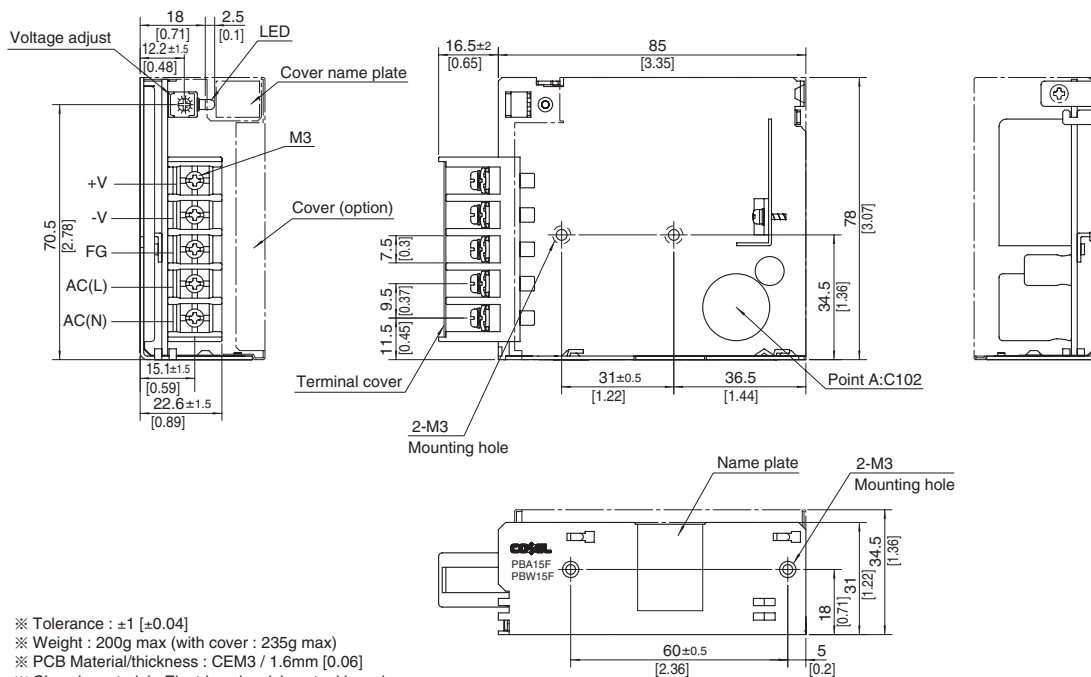

- ※ Tolerance : ±1 [±0.04]
- ※ Weight : 200g max (with cover : 235g max)
- ※ PCB Material/thickness : CEM3 / 1.6mm [0.06]
- ※ Chassis material : Electric galvanizing steel board
- ※ Dimensions in mm, [ ] = inches
- ※ Mounting torque : 0.6N • m(6.3kgf • cm)max
- ※ Screw tightening torque : M3 0.8N • m(8.5kgf • cm)max
- ※ Please connect safety ground to the unit in 2-M3 holes.



# PBA30F

PB A 30 F -□ -□  
 ① ② ③ ④ ⑤ ⑥

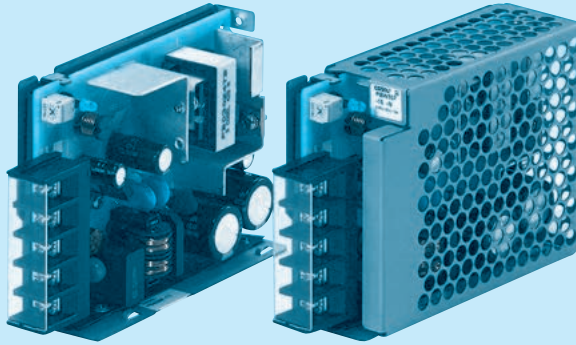
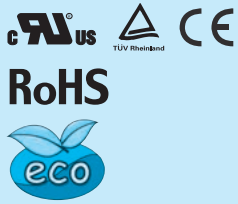

Example recommended EMI/EMC filter  
**NAC-06-472**



High voltage pulse noise type : NAP series  
 Low leakage current type : NAM series  
 \*A higher current rating EMI/EMC filter may be recommended in view of the other devices that could be connected in parallel with the power supply.

- ① Series name
- ② Single output
- ③ Output wattage
- ④ Universal input
- ⑤ Output voltage
- ⑥ Optional \*5
- C : with Coating
- G : Low leakage current
- E : Low leakage current and EMI class A
- T : Vertical terminal block
- J1 : VH (J.S.T.) connector type
- N : with Cover (UL508 is acquired [5V, 12V, 24V])
- N1 : with DIN rail and Cover
- V : Output voltage setting potentiometer externally

Cover is optional

\*Make sure necessary tests will be carried out on your end equipment with the power supply installed in accordance with any required EMC/EMI regulations.

MODEL	PBA30F-3R3	PBA30F-5	PBA30F-9	PBA30F-12	PBA30F-15	PBA30F-24	PBA30F-48
MAX OUTPUT WATTAGE[W]	19.8	30	30.6	30	30	31.2	31.2
DC OUTPUT	3.3V 6A	5V 6A	9V 3.4A	12V 2.5A	15V 2A	24V 1.3A	48V 0.65A

## SPECIFICATIONS

	MODEL	PBA30F-3R3	PBA30F-5	PBA30F-9	PBA30F-12	PBA30F-15	PBA30F-24	PBA30F-48	
INPUT	VOLTAGE[V]	AC85 - 264 1 φ or DC110 - 370 (AC50 or DC70 Please refer to the instruction manual 1.1 Input voltage *3)							
	CURRENT[A]	ACIN 100V	0.50typ (Io=100%)		0.70typ (Io=100%)				
		ACIN 200V	0.30typ (Io=100%)		0.40typ (Io=100%)				
	FREQUENCY[Hz]	50/60 (47 - 440) or DC							
	EFFICIENCY[%]	ACIN 100V	68typ	74typ	75typ	76typ	78typ	78typ	79typ
		ACIN 200V	69typ	77typ	77typ	78typ	81typ	81typ	81typ
	INRUSH CURRENT[A]	ACIN 100V	15typ (Io=100%) (At cold start)						
	ACIN 200V	30typ (Io=100%) (At cold start)							
LEAKAGE CURRENT[ma]	0.30/0.65max (ACIN 100V/240V 60Hz, Io=100%, According to IEC60950-1.DENAN)								
OUTPUT	VOLTAGE[V]	3.3	5	9	12	15	24	48	
	CURRENT[A]	6	6	3.4	2.5	2	1.3	0.65	
	LINE REGULATION[mV] *6	20max	20max	36max	48max	60max	96max	192max	
	LOAD REGULATION[mV] *6	40max	40max	100max	100max	120max	150max	240max	
	RIPPLE[mVp-p]	0 to +50°C *1	80max	80max	120max	120max	120max	120max	150max
		-10 - 0°C *1	140max	140max	160max	160max	160max	160max	200max
	RIPPLE NOISE[mVp-p]	0 to +50°C *1	120max	120max	150max	150max	150max	150max	250max
		-10 - 0°C *1	160max	160max	180max	180max	180max	180max	300max
	TEMPERATURE REGULATION[mV]	0 to +50°C	50max	50max	90max	120max	150max	240max	480max
		-10 to +50°C	60max	60max	120max	150max	180max	290max	600max
	DRIFT[mV] *2	20max	20max	36max	48max	60max	96max	192max	
	START-UP TIME[ms]	200typ(ACIN 100V, Io=100%) *Start-up time is 700ms typ for less than 1minute of applying input again from turning off the input voltage.							
HOLD-UP TIME[ms]	20typ (ACIN 100V, Io=100%)								
OUTPUT VOLTAGE ADJUSTMENT RANGE[V]	2.85 - 3.60	4.50 - 5.50	7.50 - 10.0	10.0 - 13.2	13.2 - 18.0	19.2 - 27.0	39.0 - 53.0		
OUTPUT VOLTAGE SETTING[V]	3.30 - 3.40	5.00 - 5.15	9.00 - 9.36	12.00 - 12.48	15.00 - 15.60	24.00 - 24.96	48.00 - 49.92		
PROTECTION CIRCUIT AND OTHERS	OVERCURRENT PROTECTION	Works over 105% of rated current and recovers automatically							
	OVERVOLTAGE PROTECTION[V]	4.00 - 5.25	5.75 - 7.00	11.5 - 14.0	15.0 - 18.0	20.0 - 25.0	30.0 - 37.0	58.0 - 65.0	
	OPERATING INDICATION	LED (Green)							
	REMOTE ON/OFF	None							
ISOLATION	INPUT-OUTPUT	AC3,000V 1minute, Cutoff current = 10mA, DC500V 50MΩmin (At Room Temperature)							
	INPUT-FG	AC2,000V 1minute, Cutoff current = 10mA, DC500V 50MΩmin (At Room Temperature)							
	OUTPUT-FG	AC500V 1minute, Cutoff current = 25mA, DC500V 50MΩmin (At Room Temperature)							
ENVIRONMENT	OPERATING TEMP.,HUMID.AND ALTITUDE	-10 to +71°C (Refer to "Derating"), 20 - 90%RH (Non condensing) 3,000m (10,000feet) max							
	STORAGE TEMP.,HUMID.AND ALTITUDE	-20 to +75°C, 20 - 90%RH (Non condensing) 9,000m (30,000feet) max							
	VIBRATION	10 - 55Hz, 19.6m/s <sup>2</sup> (2G), 3minutes period, 60minutes each along X, Y and Z axis							
	IMPACT	196.1m/s <sup>2</sup> (20G), 11ms, once each X, Y and Z axis							
SAFETY AND NOISE REGULATIONS	AGENCY APPROVALS (At only AC input)	UL60950-1, C-UL(CSA60950-1), EN60950-1, EN50178 Complies with DEN-AN							
	CONDUCTED NOISE	Complies with FCC Part15 classB, VCCI-B, CISPR22-B, EN55011-B, EN55022-B							
	HARMONIC ATTENUATOR	Complies with IEC61000-3-2 (Not built-in to active filter *4) *7							
OTHERS	CASE SIZE/WEIGHT	31 × 78 × 103mm [1.22 × 3.07 × 4.06 inches] (without terminal block) (W × H × D) / 270g max (with cover : 310g max)							
	COOLING METHOD	Convection							

\*1 Measured by 20MHz oscilloscope or Ripple-Noise meter(equivalent to KEISOKU-GIKEN :RM101).  
 \*2 Drift is the change in DC output for an eight hour period after a half-hour warm-up at 25°C.  
 \*3 Derating is required.  
 \*4 When two or more units are used,they may not comply with the harmonic attenuator. Please contact us for details.

\*5 Please contact us about safety approvals for the model with option.  
 \*6 Please contact us about dynamic load and input response.  
 \*7 Please contact us about class C.  
 \* Parallel operation with other model is not possible.  
 \* Derating is required when operated with cover.  
 \* A sound may occur from power supply at peak loading.

Block diagram

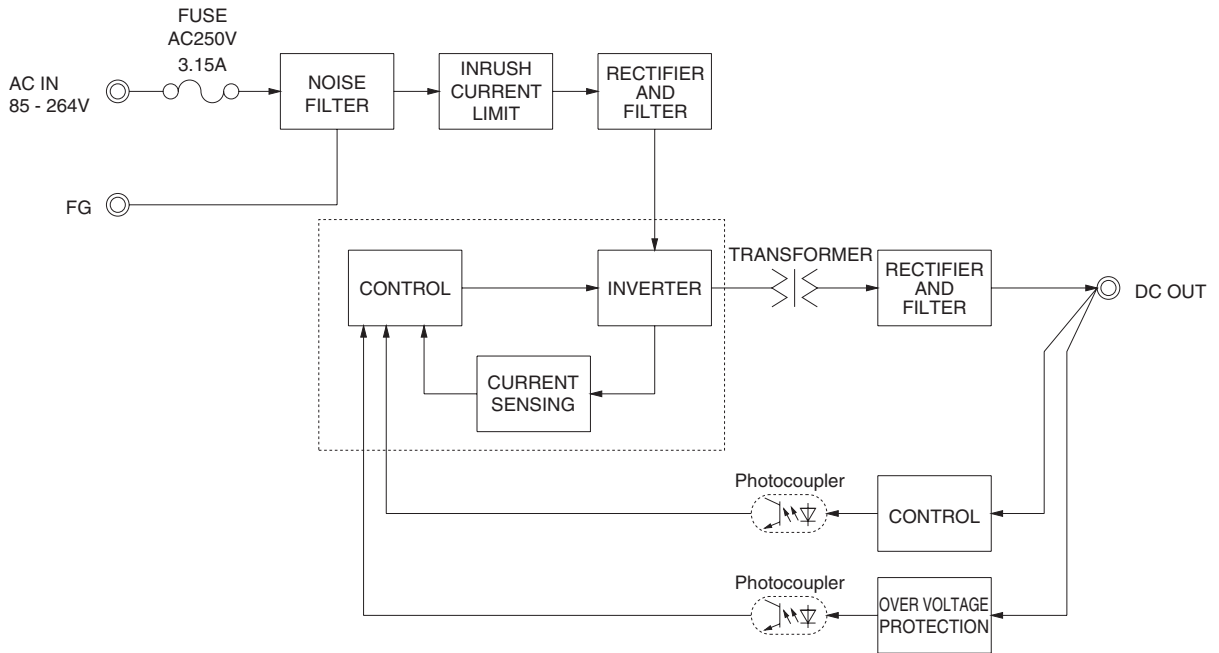

External view

※ External size of option T,J1,N1 and V is different from standard model and refer to 7 Option of instruction manual for details.

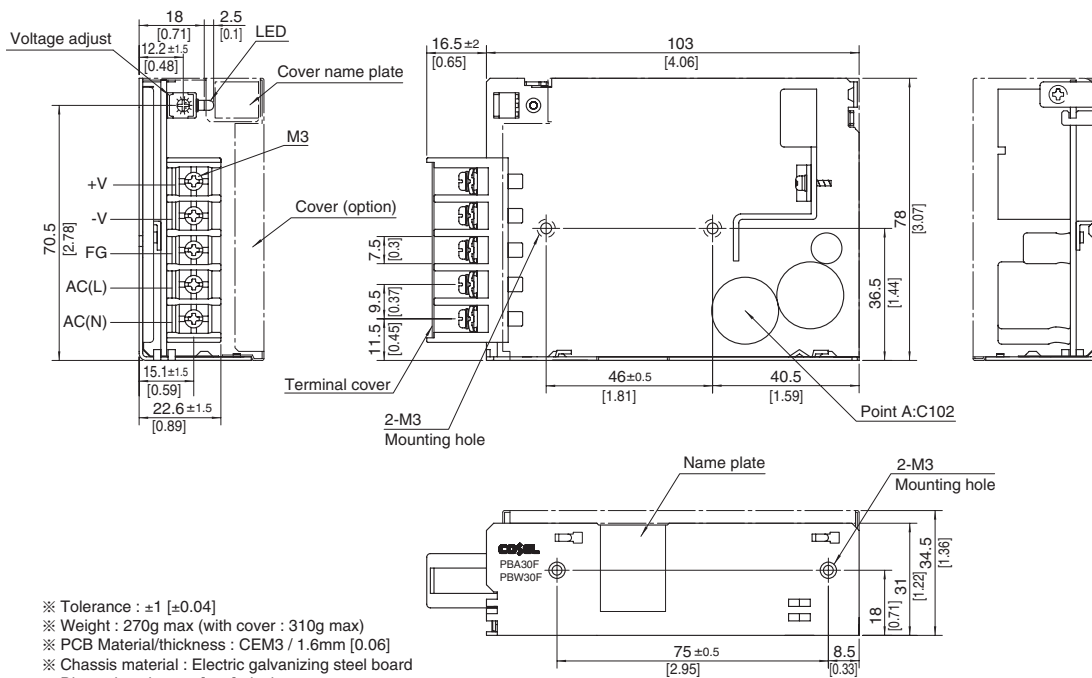

- ※ Tolerance :  $\pm 1$  [ $\pm 0.04$ ]
- ※ Weight : 270g max (with cover : 310g max)
- ※ PCB Material/thickness : CEM3 / 1.6mm [0.06]
- ※ Chassis material : Electric galvanizing steel board
- ※ Dimensions in mm, [ ] = inches
- ※ Mounting torque : 0.6N • m (6.3kgf • cm) max
- ※ Screw tightening torque : M3 0.8N • m (8.5kgf • cm) max
- ※ Please connect safety ground to the unit in 2-M3 holes.



# PBA50F

PB A 50 F -5 -□

① ② ③ ④ ⑤ ⑥

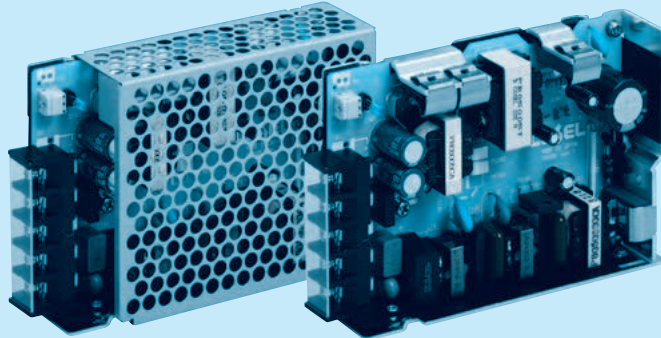
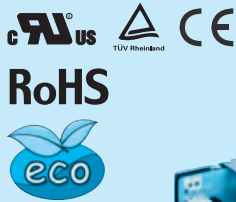

Example recommended EMI/EMC filter  
NAC-06-472



High voltage pulse noise type : NAP series  
Low leakage current type : NAM series  
\* A higher current rating EMI/EMC filter may be recommended in view of the other devices that could be connected in parallel with the power supply.

- ① Series name
- ② Single output
- ③ Output wattage
- ④ Universal input
- ⑤ Output voltage
- ⑥ Optional \*5
- C :with Coating
- G :Low leakage current (0.15mA max / ACIN 240V)
- E :Low leakage current and EMI class A (0.5mA max / ACIN 240V)
- T :Vertical terminal block
- J1 :VH (J.S.T.) connector type
- R :with Remote ON/OFF
- N :with Cover (Only 24V UL508 is acquired)
- N1 :with DIN rail and Cover
- V :Output voltage setting potentiometer external-ly

Cover is optional

\*Make sure necessary tests will be carried out on your end equipment with the power supply installed in accordance with any required EMC/EMI regulations.

MODEL	PBA50F-3R3	PBA50F-5	PBA50F-9	PBA50F-12	PBA50F-15	PBA50F-24	PBA50F-36	PBA50F-48
MAX OUTPUT WATTAGE[W]	33	50	50.4	51.6	52.5	52.8	50.4	52.8
DC OUTPUT	3.3V 10A	5V 10A	9V 5.6A	12V 4.3A	15V 3.5A	24V 2.2A	36V 1.4A	48V 1.1A

## SPECIFICATIONS

MODEL	PBA50F-3R3	PBA50F-5	PBA50F-9	PBA50F-12	PBA50F-15	PBA50F-24	PBA50F-36	PBA50F-48
<b>INPUT</b>	AC85 - 264 1 φ or DC120 - 370 (AC50 or DC70 Please refer to the instruction manual 1.1 Input voltage *4)							
CURRENT[A]	ACIN 100V	0.5typ	0.7typ					
	ACIN 200V	0.3typ	0.4typ					
FREQUENCY[Hz]	50/60 (47 - 63)							
EFFICIENCY[%]	ACIN 100V	75typ	80typ	79typ	80typ	81typ	82typ	83typ
	ACIN 200V	76typ	82typ	81typ	82typ	83typ	84typ	85typ
POWER FACTOR(lo=100%)	ACIN 100V	0.98typ	0.99typ					
	ACIN 200V	0.87typ	0.93typ					
INRUSH CURRENT[A]	ACIN 100V	15typ (lo=100%) (At cold start)						
	ACIN 200V	30typ (lo=100%) (At cold start)						
LEAKAGE CURRENT[mA]	0.4/0.75max (ACIN 100V/240V 60Hz, lo=100%, According to IEC60950-1.DENAN)							
<b>OUTPUT</b>	VOLTAGE[V]	3.3	5	9	12	15	24	36
	CURRENT[A]	10	10	5.6	4.3	3.5	2.2	1.4
	LINE REGULATION[mV]	20max	20max	36max	48max	60max	96max	144max
	LOAD REGULATION[mV]	40max	40max	100max	100max	120max	150max	240max
RIPPLE[mVp-p]	0 to +50°C *1	80max	80max	120max	120max	120max	120max	150max
	-10 - 0°C *1	140max	140max	160max	160max	160max	160max	200max
RIPPLE NOISE[mVp-p]	0 to +50°C *1	120max	120max	150max	150max	150max	150max	250max
	-10 - 0°C *1	160max	160max	180max	180max	180max	180max	300max
TEMPERATURE REGULATION[mV]	0 to +50°C	50max	50max	90max	120max	150max	240max	360max
	-10 to +50°C	60max	60max	120max	150max	180max	290max	450max
DRIFT[mV]	*2	20max	20max	36max	48max	60max	96max	144max
START-UP TIME[ms]	350typ(ACIN 100V, lo=100%)							
HOLD-UP TIME[ms]	20typ (ACIN 100V, lo=100%)							
OUTPUT VOLTAGE ADJUSTMENT RANGE[V]	2.85 - 3.63		4.00 - 5.50		7.50 - 10.0		10.0 - 13.2	
OUTPUT VOLTAGE SETTING[V]	3.30 - 3.40		5.00 - 5.15		9.00 - 9.36		12.00 - 12.48	
OVERCURRENT PROTECTION	Works over 105% of rated current and recovers automatically							
	OVERVOLTAGE PROTECTION[V]	4.00 - 5.25	5.75 - 7.00	11.5 - 14.0	15.0 - 18.0	20.0 - 25.0	30.0 - 37.0	43.0 - 50.0
OPERATING INDICATION	LED (Green)							
REMOTE ON/OFF	Optional (Required external power source)							
ISOLATION	INPUT-OUTPUT - RC	*3 AC3.000V 1minute, Cutoff current = 10mA, DC500V 50MΩmin (At Room Temperature)						
	INPUT-FG	AC2.000V 1minute, Cutoff current = 10mA, DC500V 50MΩmin (At Room Temperature)						
OUTPUT - RC-FG	*3 AC500V 1minute, Cutoff current = 100mA, DC500V 50MΩmin (At Room Temperature)							
ENVIRONMENT	OPERATING TEMP.,HUMID.AND ALTITUDE	-10 to +71°C (Refer to "Derating"), 20 - 90%RH (Non condensing) 3,000m (10,000feet) max						
	STORAGE TEMP.,HUMID.AND ALTITUDE	-20 to +75°C, 20 - 90%RH (Non condensing) 9,000m (30,000feet) max						
SAFETY AND NOISE REGULATIONS	VIBRATION	10 - 55Hz, 19.6m/s <sup>2</sup> (2G), 3minutes period, 60minutes each along X, Y and Z axis						
	IMPACT	196.1m/s <sup>2</sup> (20G), 11ms, once each X, Y and Z axis						
OTHERS	AGENCY APPROVALS (At only AC input)	UL60950-1, C-UL(CSA60950-1), EN60950-1, EN50178 Complies with DEN-AN						
	CONDUCTED NOISE	Complies with FCC Part15 classB, VCCI-B, CISPR22-B, EN55011-B, EN55022-B						
	HARMONIC ATTENUATOR	Complies with IEC61000-3-2 *6						
CASE SIZE/WEIGHT	31 x 82 x 120mm [1.22 x 3.23 x 4.72 inches] (without terminal block) (W x H x D) / 280g max (with cover : 325g max)							
COOLING METHOD	Convection							

\*1 Measured by 20MHz oscilloscope or Ripple-Noise meter(equivalent to KEISOKU-GIKEN :RM101).  
 \*2 Drift is the change in DC output for an eight hour period after a half-hour warm-up at 25°C.  
 \*3 Applicable when Remote ON/OFF(optional) is added. RC is insulated with input, output and FG.  
 \*4 Derating is required.

\*5 Please contact us about safety approvals for the model with option.  
 \*6 Please contact us about class C.  
 \* Parallel operation with other model is not possible.  
 \* Derating is required when operated with cover.  
 \* A sound may occur from power supply at peak loading.

## Block diagram

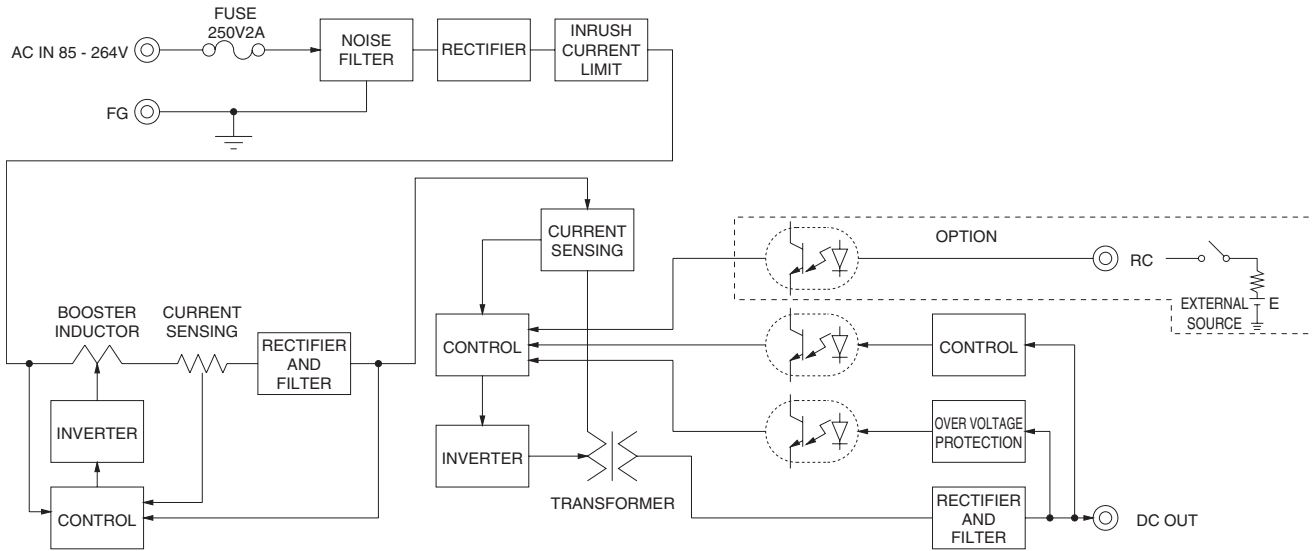

## External view

※ External size of option T,J1,R,N1 and V is different from standard model and refer to 7 Option of instruction manual for details.

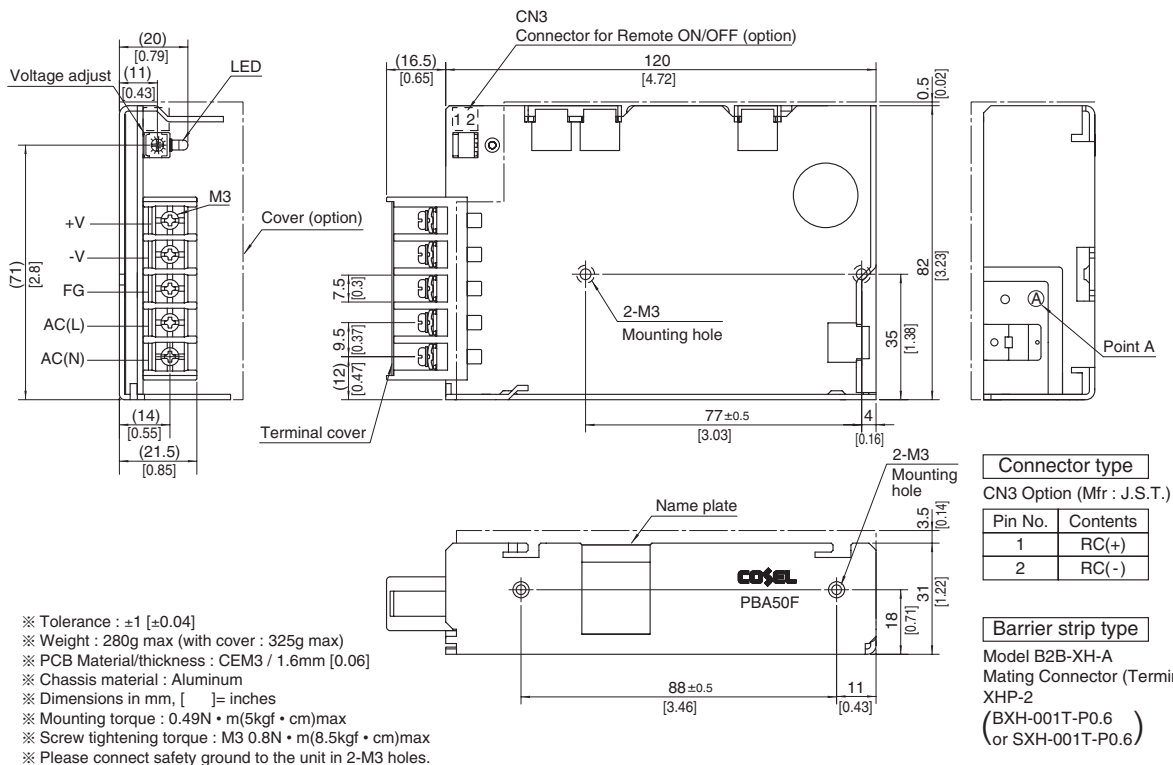

# PBA75F

PB A 75 F -5 -□

① ② ③ ④ ⑤ ⑥

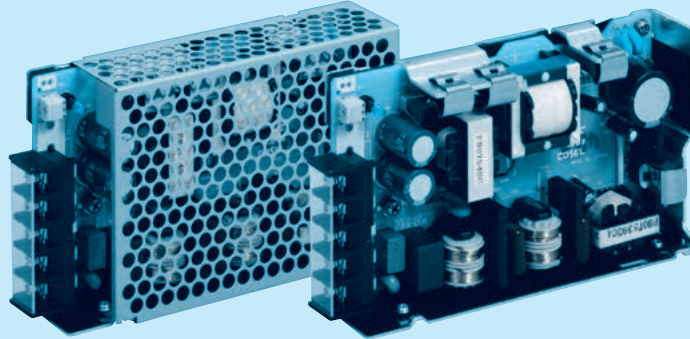
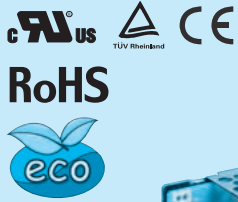

Example recommended EMI/EMC filter  
NAC-06-472



High voltage pulse noise type : NAP series  
Low leakage current type : NAM series  
\* A higher current rating EMI/EMC filter may be recommended in view of the other devices that could be connected in parallel with the power supply.

- ① Series name
- ② Single output
- ③ Output wattage
- ④ Universal input
- ⑤ Output voltage
- ⑥ Optional \*5
- C :with Coating
- G :Low leakage current (0.15mA max / ACIN 240V)
- E :Low leakage current and EMI class A (0.5mA max / ACIN 240V)
- T :Vertical terminal block
- J1 :VH (J.S.T.) connector type
- R :with Remote ON/OFF
- N :with Cover (Only 24V UL508 is acquired)
- N1 :with DIN rail and Cover
- V :Output voltage setting potentiometer externaly

Cover is optional

\*Make sure necessary tests will be carried out on your end equipment with the power supply installed in accordance with any required EMC/EMI regulations.

MODEL	PBA75F-3R3	PBA75F-5	PBA75F-9	PBA75F-12	PBA75F-15	PBA75F-24	PBA75F-36	PBA75F-48
MAX OUTPUT WATTAGE[W]	49.5	75	75.6	75.6	75	76.8	75.6	76.8
DC OUTPUT	3.3V 15A	5V 15A	9V 8.4A	12V 6.3A	15V 5A	24V 3.2A	36V 2.1A	48V 1.6A

## SPECIFICATIONS

MODEL	PBA75F-3R3	PBA75F-5	PBA75F-9	PBA75F-12	PBA75F-15	PBA75F-24	PBA75F-36	PBA75F-48		
INPUT	VOLTAGE[V] AC85 - 264 1 φ or DC120 - 370 (AC50 or DC70 Please refer to the instruction manual 1.1 Input voltage *4)									
	CURRENT[A]	ACIN 100V	0.7typ	1.0typ						
		ACIN 200V	0.4typ	0.5typ						
	FREQUENCY[Hz]	50/60 (47 - 63)								
	EFFICIENCY[%]	ACIN 100V	77typ	81typ	80typ	81typ	82typ	83typ	84typ	
		ACIN 200V	78typ	83typ	82typ	83typ	84typ	85typ	86typ	
	POWER FACTOR(lo=100%)	ACIN 100V	0.98typ	0.99typ						
ACIN 200V		0.87typ	0.93typ							
INRUSH CURRENT[A]	ACIN 100V	15typ (lo=100%) (At cold start)								
	ACIN 200V	30typ (lo=100%) (At cold start)								
LEAKAGE CURRENT[mA]	0.4/0.75max (ACIN 100V/240V 60Hz, lo=100%, According to IEC60950-1.DENAN)									
OUTPUT	VOLTAGE[V]	3.3	5	9	12	15	24	36	48	
	CURRENT[A]	15	15	8.4	6.3	5	3.2	2.1	1.6	
	LINE REGULATION[mV]	20max	20max	36max	48max	60max	96max	144max	192max	
	LOAD REGULATION[mV]	40max	40max	100max	100max	120max	150max	240max	240max	
	RIPPLE[mVp-p]	0 to +50°C *1	80max	80max	120max	120max	120max	120max	150max	150max
		-10 - 0°C *1	140max	140max	160max	160max	160max	160max	200max	200max
	RIPPLE NOISE[mVp-p]	0 to +50°C *1	120max	120max	150max	150max	150max	150max	250max	250max
		-10 - 0°C *1	160max	160max	180max	180max	180max	180max	300max	300max
	TEMPERATURE REGULATION[mV]	0 to +50°C	50max	50max	90max	120max	150max	240max	360max	480max
		-10 to +50°C	60max	60max	120max	150max	180max	290max	450max	600max
	DRIFT[mV]	*2	20max	20max	36max	48max	60max	96max	144max	192max
START-UP TIME[ms]	350typ(ACIN 100V, lo=100%)									
HOLD-UP TIME[ms]	20typ (ACIN 100V, lo=100%)									
OUTPUT VOLTAGE ADJUSTMENT RANGE[V]	2.85 - 3.63	4.00 - 5.50	7.50 - 10.0	10.0 - 13.2	13.2 - 18.0	19.2 - 27.0	28.8 - 39.6	39.0 - 53.0		
OUTPUT VOLTAGE SETTING[V]	3.30 - 3.40	5.00 - 5.15	9.00 - 9.36	12.00 - 12.48	15.00 - 15.60	24.00 - 24.96	36.00 - 37.44	48.00 - 49.92		
PROTECTION CIRCUIT AND OTHERS	OVERCURRENT PROTECTION	Works over 105% of rated current and recovers automatically								
	OVERVOLTAGE PROTECTION[V]	4.00 - 5.25	5.75 - 7.00	11.5 - 14.0	15.0 - 18.0	20.0 - 25.0	30.0 - 37.0	43.0 - 50.0	58.0 - 65.0	
	OPERATING INDICATION	LED (Green)								
REMOTE ON/OFF	Optional (Required external power source)									
ISOLATION	INPUT-OUTPUT - RC	*3 AC3.000V 1minute, Cutoff current = 10mA, DC500V 50MΩmin (At Room Temperature)								
	INPUT-FG	AC2.000V 1minute, Cutoff current = 10mA, DC500V 50MΩmin (At Room Temperature)								
	OUTPUT - RC-FG	*3 AC500V 1minute, Cutoff current = 100mA, DC500V 50MΩmin (At Room Temperature)								
ENVIRONMENT	OPERATING TEMP.,HUMID.AND ALTITUDE	-10 to +71°C (Refer to "Derating"), 20 - 90%RH (Non condensing) 3,000m (10,000feet) max								
	STORAGE TEMP.,HUMID.AND ALTITUDE	-20 to +75°C; 20 - 90%RH (Non condensing) 9,000m (30,000feet) max								
	VIBRATION	10 - 55Hz, 19.6m/s <sup>2</sup> (2G), 3minutes period, 60minutes each along X, Y and Z axis								
IMPACT	196.1m/s <sup>2</sup> (20G), 11ms, once each X, Y and Z axis									
SAFETY AND NOISE REGULATIONS	AGENCY APPROVALS (At only AC input)	UL60950-1, C-UL(CSA60950-1), EN60950-1, EN50178 Complies with DEN-AN								
	CONDUCTED NOISE	Complies with FCC Part15 classB, VCCI-B, CISPR22-B, EN55011-B, EN55022-B								
	HARMONIC ATTENUATOR	Complies with IEC61000-3-2 *6								
OTHERS	CASE SIZE/WEIGHT	32 x 82 x 135mm [1.26 x 3.23 x 5.31 inches] (without terminal block) (W x H x D) / 350g max (with cover : 400g max)								
	COOLING METHOD	Convection								

\*1 Measured by 20MHz oscilloscope or Ripple-Noise meter(equivalent to KEISOKU-GIKEN :RM101).  
 \*2 Drift is the change in DC output for an eight hour period after a half-hour warm-up at 25°C.  
 \*3 Applicable when Remote ON/OFF(optional) is added. RC is insulated with input, output and FG.  
 \*4 Derating is required.

\*5 Please contact us about safety approvals for the model with option.  
 \*6 Please contact us about class C.  
 \* Parallel operation with other model is not possible.  
 \* Derating is required when operated with cover.  
 \* A sound may occur from power supply at peak loading.

Block diagram

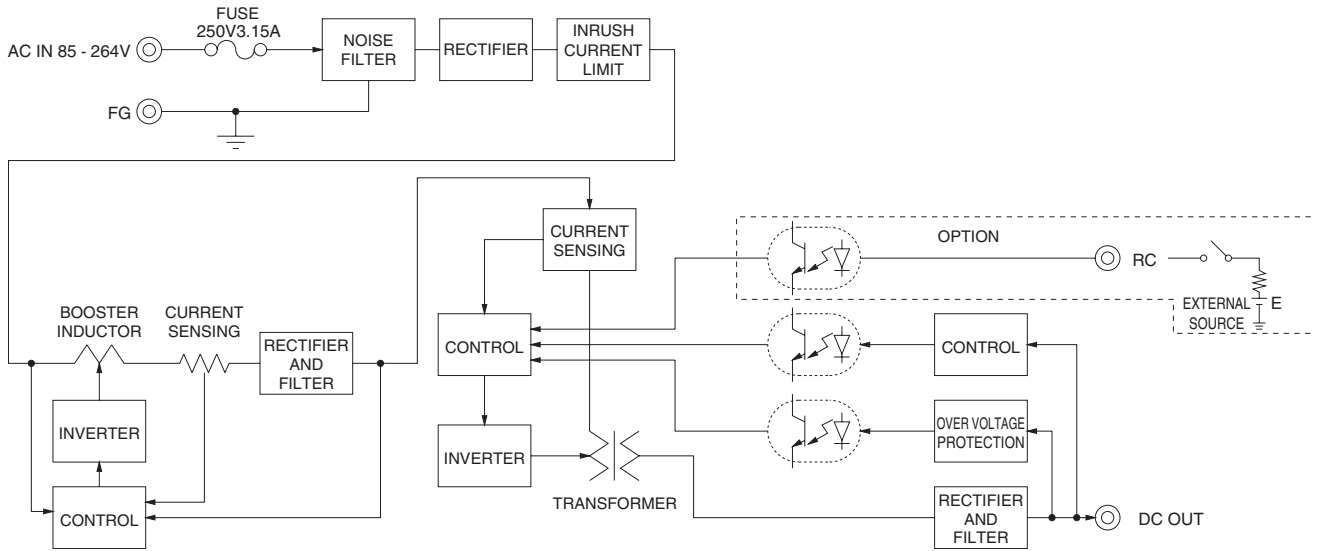

External view

※ External size of option T, J1, R, N1 and V is different from standard model and refer to 7 Option of instruction manual for details.

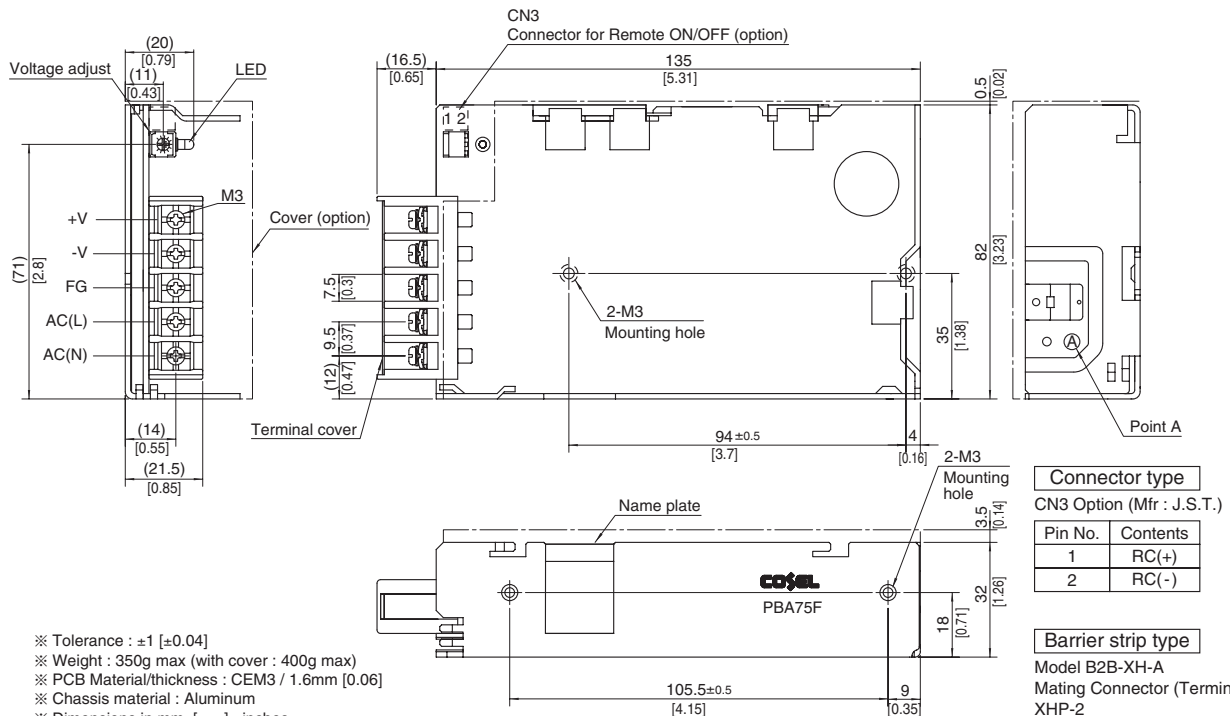

Connector type  
CN3 Option (Mfr : J.S.T.)

Pin No.	Contents
1	RC(+)
2	RC(-)

Barrier strip type  
Model B2B-XH-A  
Mating Connector (Terminal)  
XHP-2  
(BXH-001T-P0.6  
or SXH-001T-P0.6)

- ※ Tolerance : ±1 [±0.04]
- ※ Weight : 350g max (with cover : 400g max)
- ※ PCB Material/thickness : CEM3 / 1.6mm [0.06]
- ※ Chassis material : Aluminum
- ※ Dimensions in mm, [ ] = inches
- ※ Mounting torque : 0.49N • m(5kgf • cm)max
- ※ Screw tightening torque : M3 0.8N • m(8.5kgf • cm)max
- ※ Please connect safety ground to the unit in 2-M3 holes.

# PBA100F

**PB A 100 F -5 -**

① ② ③ ④ ⑤ ⑥

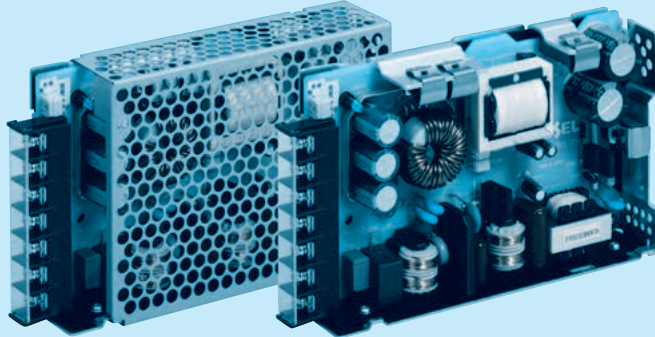

Example recommended EMI/EMC filter  
**NAC-06-472**



High voltage pulse noise type : NAP series  
Low leakage current type : NAM series  
\* A higher current rating EMI/EMC filter may be recommended in view of the other devices that could be connected in parallel with the power supply.

- ① Series name
- ② Single output
- ③ Output wattage
- ④ Universal input
- ⑤ Output voltage
- ⑥ Optional \*5
- C :with Coating
- G :Low leakage current (0.15mA max / ACIN 240V)
- E :Low leakage current and EMI class A (0.5mA max / ACIN 240V)
- T :Vertical terminal block
- J1 :VH (J.S.T.) connector type (Only -12,-15,-24,-36,-48)
- R :with Remote ON/OFF
- N :with Cover (Only 24V UL508 is acquired)
- NI :with DIN rail and Cover
- V :Output voltage setting potentiometer external-ly

Cover is optional

\* Make sure necessary tests will be carried out on your end equipment with the power supply installed in accordance with any required EMC/EMI regulations.

MODEL	PBA100F-3R3	PBA100F-5	PBA100F-9	PBA100F-12	PBA100F-15	PBA100F-24	PBA100F-36	PBA100F-48
MAX OUTPUT WATTAGE[W]	66	100	94.5	102	105	108	100.8	100.8
DC OUTPUT	3.3V 20A	5V 20A	9V 10.5A	12V 8.5A	15V 7A	24V 4.5A	36V 2.8A	48V 2.1A

## SPECIFICATIONS

MODEL	PBA100F-3R3	PBA100F-5	PBA100F-9	PBA100F-12	PBA100F-15	PBA100F-24	PBA100F-36	PBA100F-48
<b>INPUT</b>	<b>VOLTAGE[V]</b> AC85 - 264 1 φ or DC120 - 370 (AC50 or DC70 Please refer to the instruction manual 1.1 Input voltage *4) <b>CURRENT[A]</b> ACIN 100V 0.9typ 1.3typ ACIN 200V 0.5typ 0.7typ <b>FREQUENCY[Hz]</b> 50/60 (47 - 63) <b>EFFICIENCY[%]</b> ACIN 100V 77typ 82typ 80typ 81typ 83typ 84typ 84typ 84typ ACIN 200V 79typ 84typ 82typ 83typ 86typ 86typ 86typ 86typ <b>POWER FACTOR(lo=100%)</b> ACIN 100V 0.98typ 0.99typ ACIN 200V 0.87typ 0.93typ <b>INRUSH CURRENT[A]</b> ACIN 100V 20typ (lo=100%) (At cold start) ACIN 200V 40typ (lo=100%) (At cold start) <b>LEAKAGE CURRENT[mA]</b> 0.4/0.75max (ACIN 100V/240V 60Hz, lo=100%, According to IEC60950-1.DENAN)							
<b>OUTPUT</b>	<b>VOLTAGE[V]</b> 3.3 5 9 12 15 24 36 48 <b>CURRENT[A]</b> 20 20 10.5 8.5 7 4.5 2.8 2.1 <b>LINE REGULATION[mV]</b> 20max 20max 36max 48max 60max 96max 144max 192max <b>LOAD REGULATION[mV]</b> 40max 40max 100max 120max 150max 150max 240max 240max <b>RIPPLE[mVp-p]</b> 0 to +50°C *1 80max 80max 120max 120max 120max 120max 150max 150max -10 - 0°C *1 140max 140max 160max 160max 160max 160max 200max 200max <b>RIPPLE NOISE[mVp-p]</b> 0 to +50°C *1 120max 120max 150max 150max 150max 150max 250max 250max -10 - 0°C *1 160max 160max 180max 180max 180max 180max 300max 300max <b>TEMPERATURE REGULATION[mV]</b> 0 to +50°C 50max 50max 90max 120max 150max 240max 360max 480max -10 to +50°C 60max 60max 120max 150max 180max 290max 450max 600max <b>DRIFT[mV]</b> *2 20max 20max 36max 48max 60max 96max 144max 192max <b>START-UP TIME[ms]</b> 350typ (ACIN 100V, lo=100%) <b>HOLD-UP TIME[ms]</b> 20typ (ACIN 100V, lo=100%) <b>OUTPUT VOLTAGE ADJUSTMENT RANGE[V]</b> 2.85 - 3.63 4.00 - 5.50 7.50 - 10.0 10.0 - 13.2 13.2 - 18.0 19.2 - 27.0 28.8 - 39.6 39.0 - 53.0 <b>OUTPUT VOLTAGE SETTING[V]</b> 3.20 - 3.40 5.00 - 5.15 9.00 - 9.36 12.00 - 12.48 15.00 - 15.60 24.00 - 24.96 36.00 - 37.44 48.00 - 49.92							
<b>PROTECTION CIRCUIT AND OTHERS</b>	<b>OVERCURRENT PROTECTION</b> Works over 105% of rated current and recovers automatically <b>OVERVOLTAGE PROTECTION[V]</b> 4.00 - 5.25 5.75 - 7.00 11.5 - 14.0 15.0 - 18.0 20.0 - 25.0 30.0 - 37.0 43.0 - 50.0 58.0 - 65.0 <b>OPERATING INDICATION</b> LED (Green) <b>REMOTE SENSING</b> Optional (Only -3R3, -5 Option -K) <b>REMOTE ON/OFF</b> Optional (Required external power source)							
<b>ISOLATION</b>	<b>INPUT-OUTPUT - RC</b> *3 AC3.000V 1minute, Cutoff current = 10mA, DC500V 50MΩmin (At Room Temperature) <b>INPUT-FG</b> AC2.000V 1minute, Cutoff current = 10mA, DC500V 50MΩmin (At Room Temperature) <b>OUTPUT - RC-FG</b> *3 AC500V 1minute, Cutoff current = 100mA, DC500V 50MΩmin (At Room Temperature)							
<b>ENVIRONMENT</b>	<b>OPERATING TEMP., HUMID. AND ALTITUDE</b> -10 to +71°C (Refer to "Derating"), 20 - 90%RH (Non condensing) 3,000m (10,000feet) max <b>STORAGE TEMP., HUMID. AND ALTITUDE</b> -20 to +75°C, 20 - 90%RH (Non condensing) 9,000m (30,000feet) max <b>VIBRATION</b> 10 - 55Hz, 19.6m/s <sup>2</sup> (2G), 3minutes period, 60minutes each along X, Y and Z axis <b>IMPACT</b> 196.1m/s <sup>2</sup> (20G), 11ms, once each X, Y and Z axis							
<b>SAFETY AND NOISE REGULATIONS</b>	<b>AGENCY APPROVALS (At only AC input)</b> UL60950-1, C-UL(CSA60950-1), EN60950-1, EN50178 Complies with DEN-AN <b>CONDUCTED NOISE</b> Complies with FCC Part15 classB, VCCI-B, CISPR22-B, EN55011-B, EN55022-B <b>HARMONIC ATTENUATOR</b> Complies with IEC61000-3-2 *6							
<b>OTHERS</b>	<b>CASE SIZE/WEIGHT</b> 32 x 93 x 147mm [1.26 x 3.66 x 5.79 inches] (without terminal block) (W x H x D) / 440g max (with cover : 500g max) <b>COOLING METHOD</b> Convection							

\*1 Measured by 20MHz oscilloscope or Ripple-Noise meter(equivalent to KEISOKU-GIKEN :RM101).  
 \*2 Drift is the change in DC output for an eight hour period after a half-hour warm-up at 25°C.  
 \*3 Applicable when Remote ON/OFF(optional) is added. RC is insulated with input, output and FG.  
 \*4 Derating is required.

\*5 Please contact us about safety approvals for the model with option.  
 \*6 Please contact us about class C.  
 \* Parallel operation with other model is not possible.  
 \* Derating is required when operated with cover.  
 \* A sound may occur from power supply at peak loading.



## Block diagram

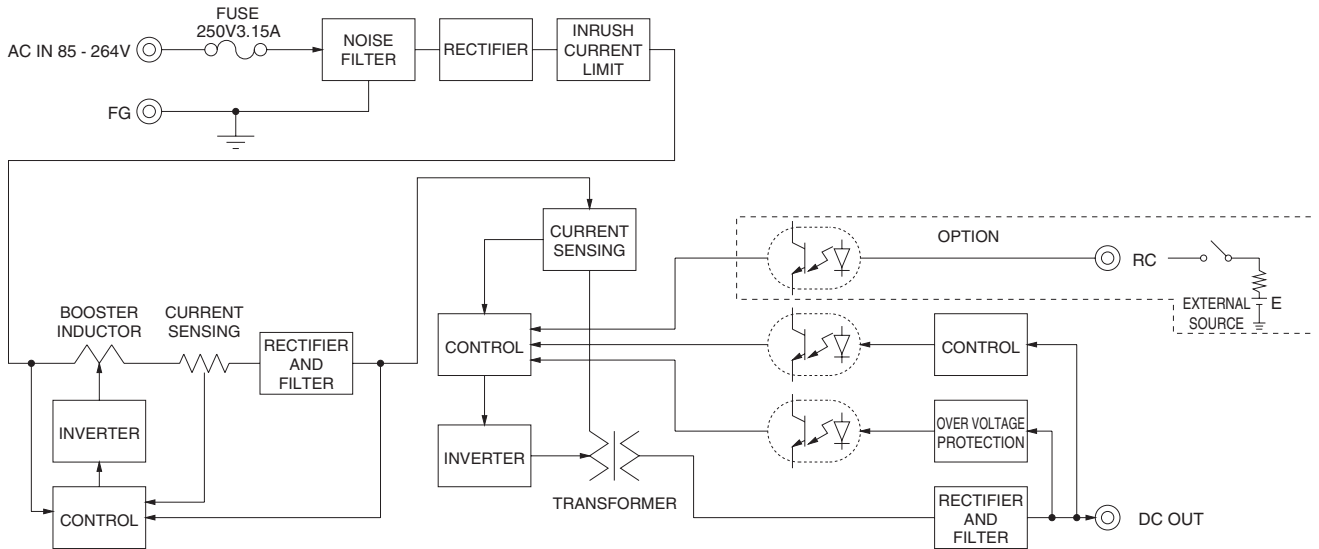

## External view

※ External size of option T,J1,R,N1,V and K is different from standard model and refer to 7 Option of instruction manual for details.

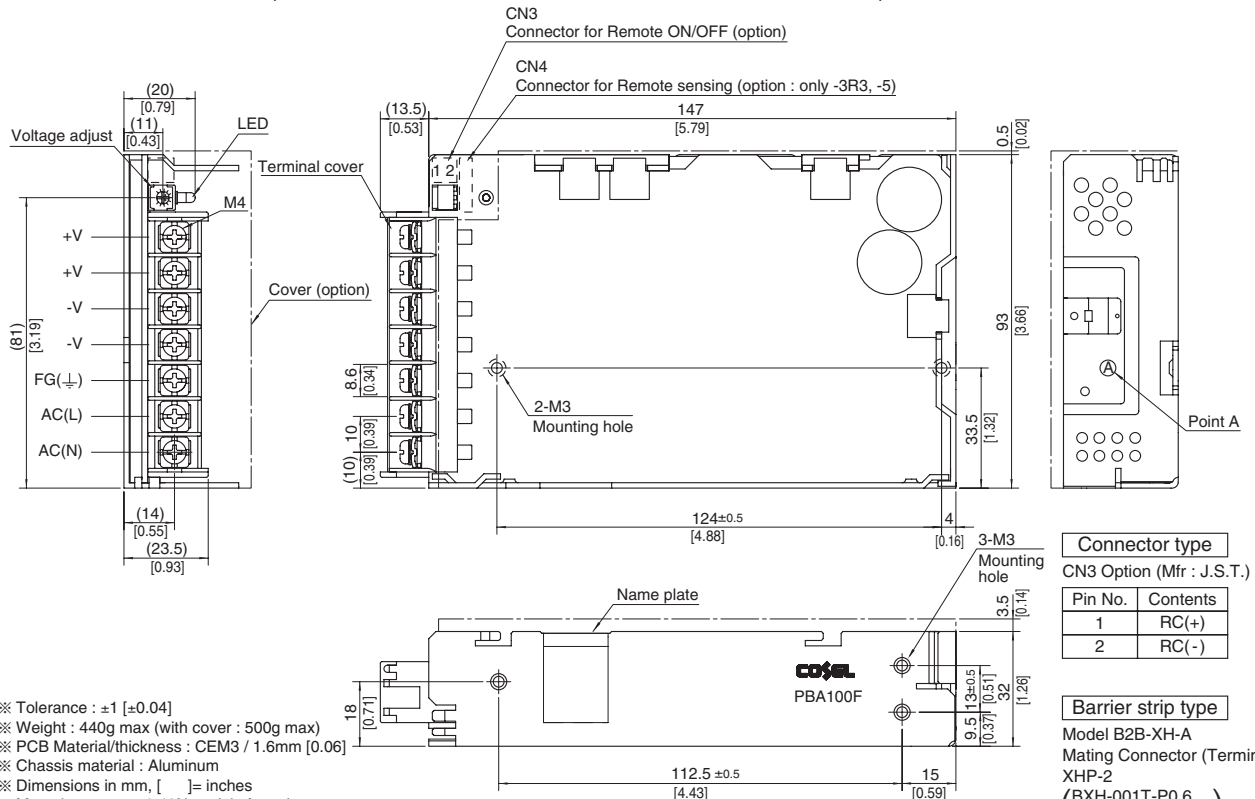

Connector type	
CN3 Option (Mfr : J.S.T.)	
Pin No.	Contents
1	RC(+)
2	RC(-)

### Barrier strip type

Model B2B-XH-A  
Mating Connector (Terminal)  
XHP-2  
(BXH-001T-P0.6  
or SXH-001T-P0.6)

- ※ Tolerance :  $\pm 1$  [ $\pm 0.04$ ]
- ※ Weight : 440g max (with cover : 500g max)
- ※ PCB Material/thickness : CEM3 / 1.6mm [ $0.06$ ]
- ※ Chassis material : Aluminum
- ※ Dimensions in mm, [ ] = inches
- ※ Mounting torque :  $0.49\text{N} \cdot \text{m}$  ( $5\text{kgf} \cdot \text{cm}$ )max
- ※ Mounting torque :  $M4:1.6\text{N} \cdot \text{m}$  ( $16.9\text{kgf} \cdot \text{cm}$ )max
- ※ Please connect safety ground to FG terminal on the unit.



# PBA150F

PB A 150 F -5 -□

① ② ③ ④ ⑤ ⑥

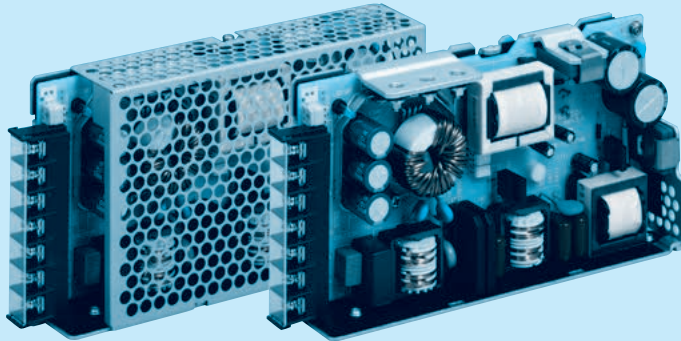
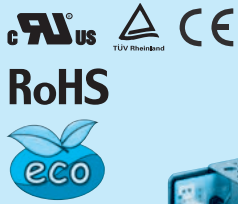

Example recommended EMI/EMC filter  
NAC-06-472



High voltage pulse noise type : NAP series  
Low leakage current type : NAM series  
\* A higher current rating EMI/EMC filter may be recommended in view of the other devices that could be connected in parallel with the power supply.

- ① Series name
- ② Single output
- ③ Output wattage
- ④ Universal input
- ⑤ Output voltage
- ⑥ Optional \*5
- C :with Coating
- G :Low leakage current (0.15mA max / ACIN 240V)
- E :Low leakage current and EMI class A (0.5mA max / ACIN 240V)
- T :Vertical terminal block
- J1 :VH (J.S.T.) connector type (Only -12,-15,-24,-36,-48)
- R :with Remote ON/OFF
- N :with Cover (Only 24V UL508 is acquired)
- NI :with DIN rail and Cover
- V :Output voltage setting potentiometer external-ly

Cover is optional

\* Make sure necessary tests will be carried out on your end equipment with the power supply installed in accordance with any required EMC/EMI regulations.

MODEL	PBA150F-3R3	PBA150F-5	PBA150F-9	PBA150F-12	PBA150F-15	PBA150F-24	PBA150F-36	PBA150F-48
MAX OUTPUT WATTAGE[W]	99	150	150.3	156	150	156	154.8	158.4
DC OUTPUT	3.3V 30A	5V 30A	9V 16.7A	12V 13A	15V 10A	24V 6.5A	36V 4.3A	48V 3.3A

## SPECIFICATIONS

	MODEL	PBA150F-3R3	PBA150F-5	PBA150F-9	PBA150F-12	PBA150F-15	PBA150F-24	PBA150F-36	PBA150F-48	
INPUT	VOLTAGE[V]	AC85 - 264 1 φ or DC120 - 370 (AC50 or DC70 Please refer to the instruction manual 1.1 Input voltage *4)								
	CURRENT[A]	ACIN 100V	1.3typ	2.0typ						
		ACIN 200V	0.7typ	1.0typ						
	FREQUENCY[Hz]	50/60 (47 - 63)								
	EFFICIENCY[%]	ACIN 100V	80typ	83typ	82typ	83typ	84typ	85typ	85typ	85typ
		ACIN 200V	82typ	86typ	85typ	86typ	87typ	88typ	88typ	88typ
	POWER FACTOR(lo=100%)	ACIN 100V	0.98typ	0.99typ						
		ACIN 200V	0.87typ	0.93typ						
	INRUSH CURRENT[A]	ACIN 100V	20typ (lo=100%) (At cold start)							
		ACIN 200V	40typ (lo=100%) (At cold start)							
LEAKAGE CURRENT[mA]	0.4/0.75max (ACIN 100V/240V 60Hz, lo=100%, According to IEC60950-1.DENAN)									
OUTPUT	VOLTAGE[V]	3.3	5	9	12	15	24	36	48	
	CURRENT[A]	30	30	16.7	13	10	6.5	4.3	3.3	
	LINE REGULATION[mV]	20max	20max	36max	48max	60max	96max	144max	192max	
	LOAD REGULATION[mV]	40max	40max	100max	100max	120max	150max	240max	240max	
	RIPPLE[mVp-p]	0 to +50°C *1	80max	80max	120max	120max	120max	120max	150max	150max
		-10 - 0°C *1	140max	140max	160max	160max	160max	160max	200max	200max
	RIPPLE NOISE[mVp-p]	0 to +50°C *1	120max	120max	150max	150max	150max	150max	250max	250max
		-10 - 0°C *1	160max	160max	180max	180max	180max	180max	300max	300max
	TEMPERATURE REGULATION[mV]	0 to +50°C	50max	50max	90max	120max	150max	240max	360max	480max
		-10 to +50°C	60max	60max	120max	150max	180max	290max	450max	600max
	DRIFT[mV]	*2	20max	20max	36max	48max	60max	96max	144max	192max
	START-UP TIME[ms]	350typ(ACIN 100V, lo=100%)								
	HOLD-UP TIME[ms]	20typ (ACIN 100V, lo=100%)								
	OUTPUT VOLTAGE ADJUSTMENT RANGE[V]	2.85 - 3.63	4.00 - 5.50	7.50 - 10.0	10.0 - 13.2	13.2 - 18.0	19.2 - 27.0	28.8 - 39.6	39.0 - 53.0	
	OUTPUT VOLTAGE SETTING[V]	3.30 - 3.40	5.00 - 5.15	9.00 - 9.36	12.00 - 12.48	15.00 - 15.60	24.00 - 24.96	36.00 - 37.44	48.00 - 49.92	
PROTECTION CIRCUIT AND OTHERS	OVERCURRENT PROTECTION	Works over 105% of rated current and recovers automatically								
	OVERVOLTAGE PROTECTION[V]	4.00 - 5.25	5.75 - 7.00	11.5 - 14.0	15.0 - 18.0	20.0 - 25.0	30.0 - 37.0	43.0 - 50.0	58.0 - 65.0	
	OPERATING INDICATION	LED (Green)								
	REMOTE SENSING	Optional (Only -3R3, -5 Option -K)								
ISOLATION	REMOTE ON/OFF	Optional (Required external power source)								
	INPUT-OUTPUT · RC	*3	AC3,000V 1minute, Cutoff current = 10mA, DC500V 50MΩmin (At Room Temperature)							
	INPUT-FG	*3	AC2,000V 1minute, Cutoff current = 10mA, DC500V 50MΩmin (At Room Temperature)							
ENVIRONMENT	OUTPUT · RC-FG	*3	AC500V 1minute, Cutoff current = 100mA, DC500V 50MΩmin (At Room Temperature)							
	OPERATING TEMP.,HUMID.AND ALTITUDE	-10 to +71°C (Refer to "Derating"), 20 - 90%RH (Non condensing) 3,000m (10,000feet) max								
	STORAGE TEMP.,HUMID.AND ALTITUDE	-20 to +75°C, 20 - 90%RH (Non condensing) 9,000m (30,000feet) max								
SAFETY AND NOISE REGULATIONS	VIBRATION	10 - 55Hz, 19.6m/s <sup>2</sup> (2G), 3minutes period, 60minutes each along X, Y and Z axis								
	IMPACT	196.1m/s <sup>2</sup> (20G), 11ms, once each X, Y and Z axis								
	AGENCY APPROVALS (At only AC input)	UL60950-1, C-UL(CSA60950-1), EN60950-1, EN50178 Complies with DEN-AN								
OTHERS	CONDUCTED NOISE	Complies with FCC Part15 classB, VCCI-B, CISPR22-B, EN55011-B, EN55022-B								
	HARMONIC ATTENUATOR	Complies with IEC61000-3-2 *6								
OTHERS	CASE SIZE/WEIGHT	34 x 93 x 168mm [1.34 x 3.66 x 6.61 inches] (without terminal block) (W x H x D) / 560g max (with cover : 630g max)								
	COOLING METHOD	Convection								

\*1 Measured by 20MHz oscilloscope or Ripple-Noise meter(equivalent to KEISOKU-GIKEN :RM101).  
 \*2 Drift is the change in DC output for an eight hour period after a half-hour warm-up at 25°C.  
 \*3 Applicable when Remote ON/OFF(optional) is added. RC is insulated with input, output and FG.  
 \*4 Derating is required.

\*5 Please contact us about safety approvals for the model with option.  
 \*6 Please contact us about class C.  
 \* Parallel operation with other model is not possible.  
 \* Derating is required when operated with cover.  
 \* A sound may occur from power supply at peak loading.

## Block diagram

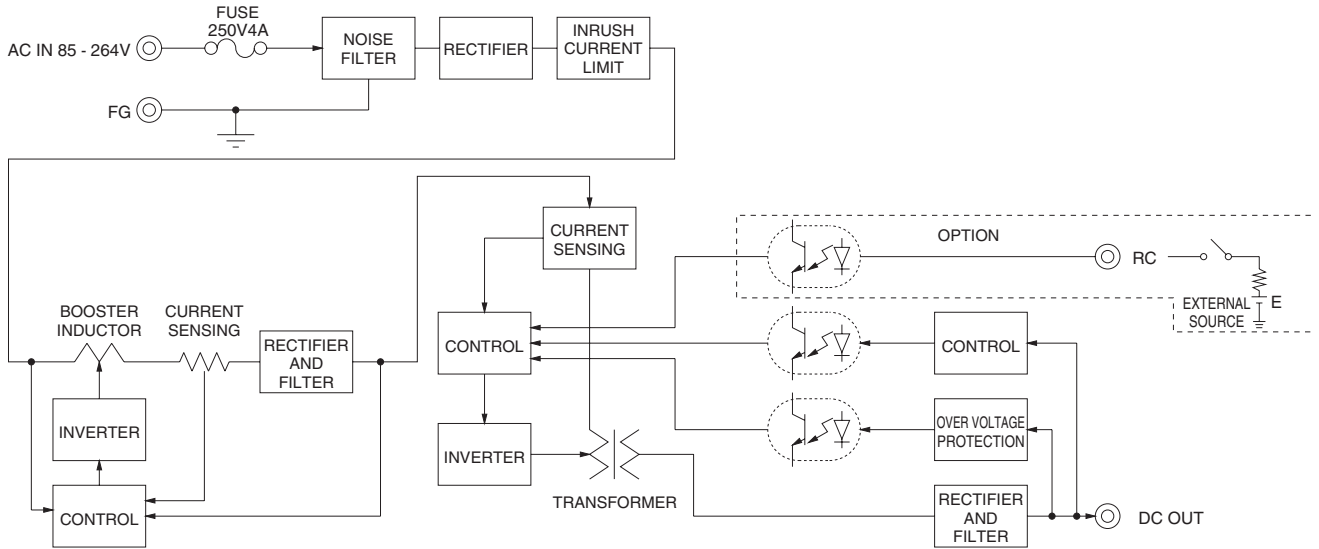

## External view

※ External size of option T, J1, R, N1, V and K is different from standard model and refer to 7 Option of instruction manual for details.

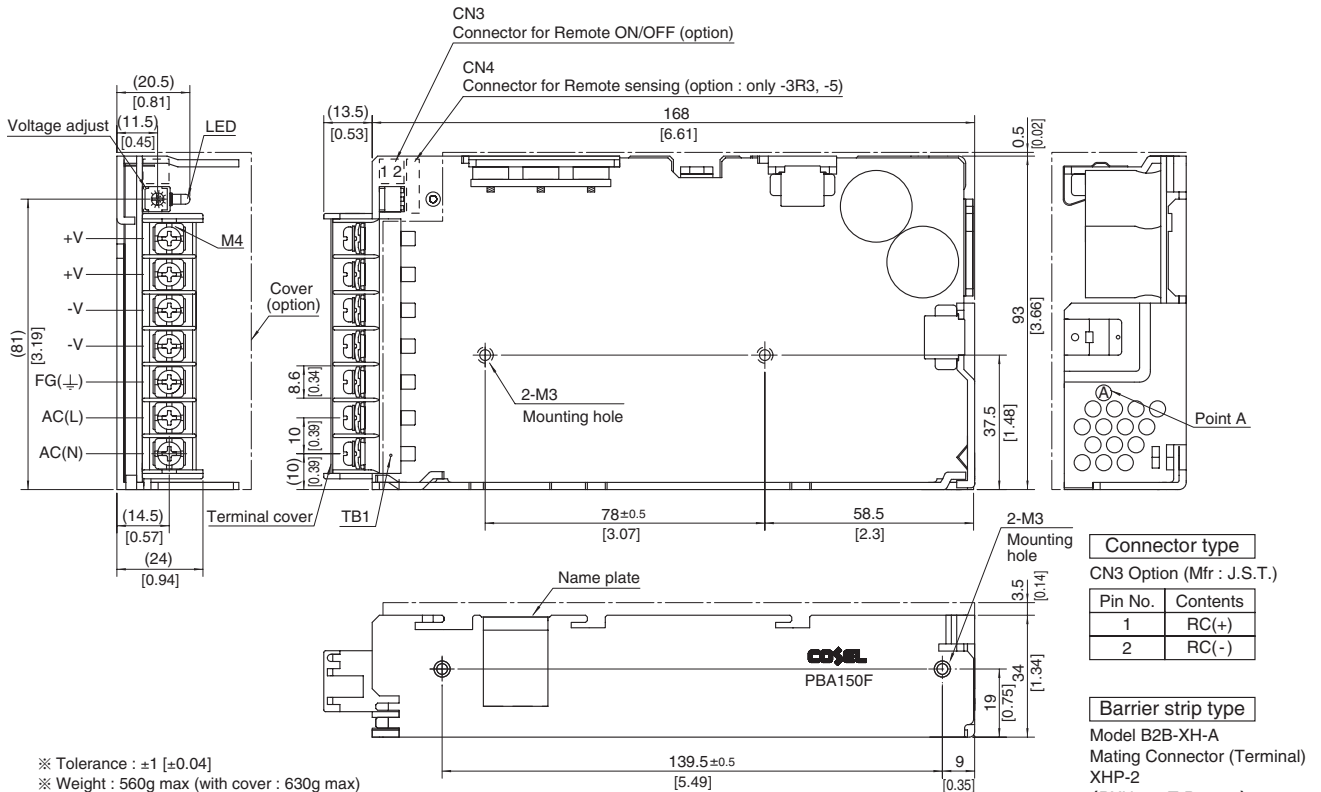

- ※ Tolerance :  $\pm 1$  [ $\pm 0.04$ ]
- ※ Weight : 560g max (with cover : 630g max)
- ※ PCB Material/thickness : CEM3 / 1.6mm [0.06]
- ※ Chassis material : Aluminum
- ※ Dimensions in mm, [ ] = inches
- ※ Mounting torque : 0.49N · m (5kgf · cm) max
- ※ Mounting torque : M4: 1.6N · m (16.9kgf · cm) max
- ※ Keep drawing current per pin below 20A for TB1.
- ※ Please connect safety ground to FG terminal on the unit.

# PBA300F

PB A 300 F -5 -□

① ② ③ ④ ⑤ ⑥

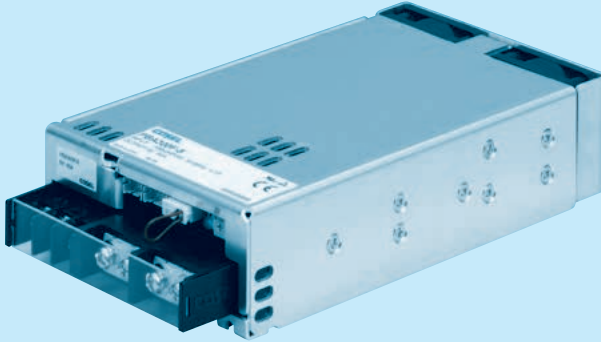
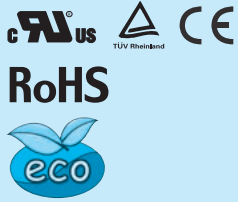

Example recommended EMI/EMC filter  
NAC-06-472



High voltage pulse noise type : NAP series  
Low leakage current type : NAM series  
\* A higher current rating EMI/EMC filter may be recommended in view of the other devices that could be connected in parallel with the power supply.

- ① Series name
- ② Single output
- ③ Output wattage
- ④ Universal input
- ⑤ Output voltage
- ⑥ Optional \*5
- C :with Coating
- G :Low leakage current
- U :Operation stop voltage is set at a lower value
- F3 :Reverse air exhaust type
- F4 :Low speed fan
- N1 :with DIN rail

Refer to instruction manual 7.1.

\*Make sure necessary tests will be carried out on your end equipment with the power supply installed in accordance with any required EMC/EMI regulations.

MODEL	PBA300F-3R3	PBA300F-5	PBA300F-7R5	PBA300F-12	PBA300F-15	PBA300F-24	PBA300F-36	PBA300F-48
MAX OUTPUT WATTAGE[W]	198	300	300	324	330	336	324	336
DC OUTPUT	ACIN 100V	3.3V 60A	5V 60A	7.5V 40A	12V 27A	15V 22A	24V 14A	36V 9A
	ACIN 200V *3	3.3V 60A	5V 60A	7.5V 40A	12V 27A	15V 22A	24V 14(16.5)A	36V 9A

## SPECIFICATIONS

MODEL	PBA300F-3R3	PBA300F-5	PBA300F-7R5	PBA300F-12	PBA300F-15	PBA300F-24	PBA300F-36	PBA300F-48		
INPUT	VOLTAGE[V]	AC85 - 264 1φ or DC120 - 350 (AC50 or DC70 Please refer to the instruction manual 7. option *4)								
	CURRENT[A]	ACIN 100V	3typ	4.1typ						
		ACIN 200V	1.6typ	2typ						
	FREQUENCY[Hz]	50/60 (47 - 63)								
	EFFICIENCY[%]	ACIN 100V	68typ	74typ	76typ	78typ	78typ	79typ	81typ	
		ACIN 200V	71typ	77typ	79typ	81typ	81typ	82typ	84typ	
	POWER FACTOR	ACIN 100V	0.98typ (Io=100%)							
ACIN 200V		0.95typ (Io=100%)								
INRUSH CURRENT[A]	ACIN 100V	20/40typ (Io=100%) (Primary inrush current /Secondary inrush current) (More then 3 sec. to re-start)								
	ACIN 200V	40/40typ (Io=100%) (Primary inrush current /Secondary inrush current) (More then 3 sec. to re-start)								
LEAKAGE CURRENT[mA]	0.45/0.75max (ACIN 100V/240V 60Hz, Io=100%, According to IEC60950-1.DENAN)									
OUTPUT	VOLTAGE[V]	3.3	5	7.5	12	15	24	36	48	
	CURRENT[A]	ACIN 100V	60	60	40	27	22	14	9	7
		ACIN 200V *3	60	60	40	27	22	14(16.5)	9	7
	LINE REGULATION[mV]	20max	20max	36max	48max	60max	96max	144max	192max	
	LOAD REGULATION[mV]	40max	40max	60max	100max	120max	150max	150max	300max	
	RIPPLE[mVp-p]	0 to +50°C *1	80max	80max	120max	120max	120max	120max	150max	150max
		-20 - 0°C *1	140max	140max	160max	160max	160max	160max	160max	400max
	RIPPLE NOISE[mVp-p]	0 to +50°C *1	120max	120max	150max	150max	150max	150max	200max	200max
		-20 - 0°C *1	160max	160max	180max	180max	180max	180max	240max	500max
	TEMPERATURE REGULATION[mV]	0 to +50°C	40max	50max	75max	120max	150max	240max	360max	480max
-20 to +50°C	60max	75max	120max	180max	180max	290max	440max	600max		
DRIFT [mV]	*2	12max	20max	30max	48max	60max	96max	144max	192max	
START-UP TIME[ms]	300typ(ACIN 100/200V, Io=100%) *Start-up time is 500ms typ for less than 1minute of applying input again from turning off the input voltage.									
HOLD-UP TIME[ms]	20typ (ACIN 100/200V, Io=100%)									
OUTPUT VOLTAGE ADJUSTMENT RANGE[V]	2.64 - 3.96	3.96 - 6.00	5.25 - 8.25	8.25 - 13.20	10.50 - 16.50	16.50 - 26.40	25.20 - 39.60	38.40 - 56.00		
OUTPUT VOLTAGE SETTING[V]	3.30 - 3.40	5.00 - 5.15	7.50 - 7.80	12.00 - 12.48	15.00 - 15.60	24.00 - 24.96	36.00 - 37.44	48.00 - 49.92		
PROTECTION CIRCUIT AND OTHERS	OVERCURRENT PROTECTION	Works over 105% of rated current or 101% of peak current and recovers automatically								
	OVERVOLTAGE PROTECTION[V]	4.3 - 6.3	6.5 - 8.0	9.0 - 11.6	14.4 - 18.6	18.0 - 23.3	28.8 - 37.2	43.2 - 54.0	57.6 - 80.0	
	OPERATING INDICATION	LED (Green)								
	REMOTE SENSING	Provided								
REMOTE ON/OFF	Provided									
ISOLATION	INPUT-OUTPUT · RC	AC3,000V 1minute, Cutoff current = 10mA, DC500V 50MΩmin (At Room Temperature)								
	INPUT-FG	AC2,000V 1minute, Cutoff current = 10mA, DC500V 50MΩmin (At Room Temperature)								
	OUTPUT · RC · AUX-FG	AC500V 1minute, Cutoff current = 100mA, DC500V 50MΩmin (At Room Temperature)								
	OUTPUT-RC · AUX	AC500V 1minute, Cutoff current = 100mA, DC500V 50MΩmin (At Room Temperature)								
ENVIRONMENT	OPERATING TEMP.,HUMID.AND ALTITUDE	-20 to +71°C (Refer to "Derating"), 20 - 90%RH (Non condensing) 3,000m (10,000feet) max								
	STORAGE TEMP.,HUMID.AND ALTITUDE	-20 to +75°C, 20 - 90%RH (Non condensing) 9,000m (30,000feet) max								
	VIBRATION	10 - 55Hz, 19.6m/s <sup>2</sup> (2G), 3minutes period, 60minutes each along X, Y and Z axis								
IMPACT	196.1m/s <sup>2</sup> (20G), 11ms, once each X, Y and Z axis									
SAFETY AND NOISE REGULATIONS	AGENCY APPROVALS (At only AC input)	UL60950-1, C-UL(CSA60950-1), EN60950-1, EN50178 Complies with DEN-AN								
	CONDUCTED NOISE	Complies with FCC Part15 classB, VCCI-B, CISPR22-B, EN55011-B, EN55022-B								
	HARMONIC ATTENUATOR	Complies with IEC61000-3-2 *6								
OTHERS	CASE SIZE/WEIGHT	102 X 42 X 170mm [4.02 X 1.65 X 6.69 inches] (without terminal block and screw) (W X H X D) /1.0kg max								
	COOLING METHOD	Forced cooling (internal fan)								

\*1 Measured by 20MHz oscilloscope or Ripple-Noise meter(equivalent to KEISOKU-GIKEN :RM101).

\*2 Drift is the change in DC output for an eight hour period after a half-hour warm-up at 25°C.  
\*3 () means peak current. Peak loading for 10s. And Duty 35% max, refer to Instruction manual in detail.

\*4 Derating is required.Consult us for details.

\*5 Please contact us about safety approvals for the model with option.

\*6 Please contact us about class C.

\* A sound may occur from power supply at pulse loading.

## Block diagram

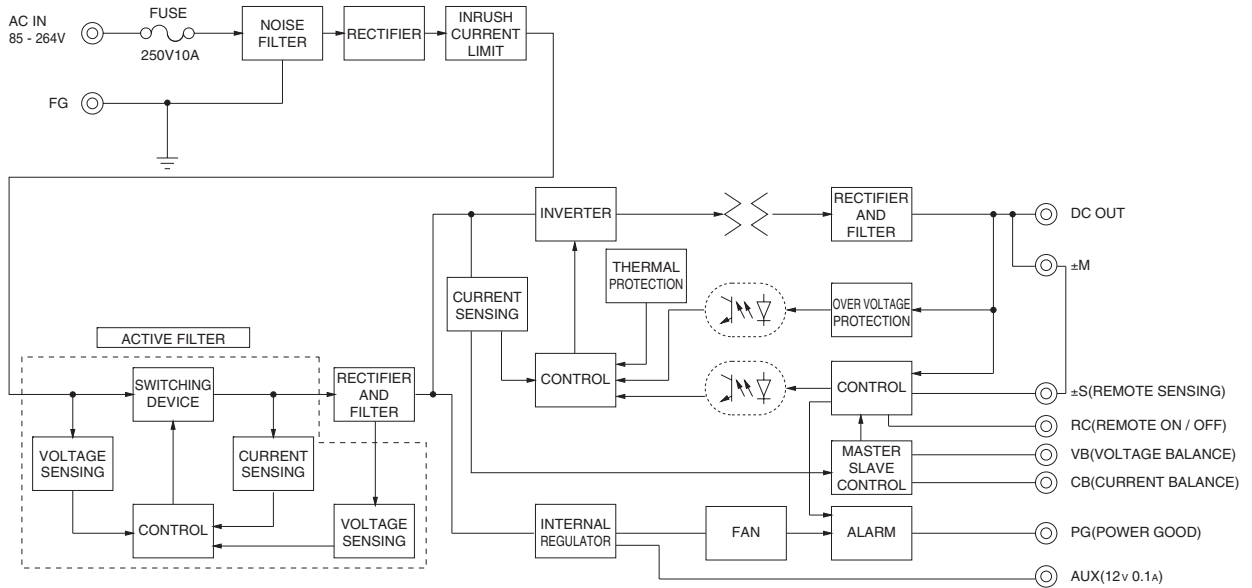

## External view

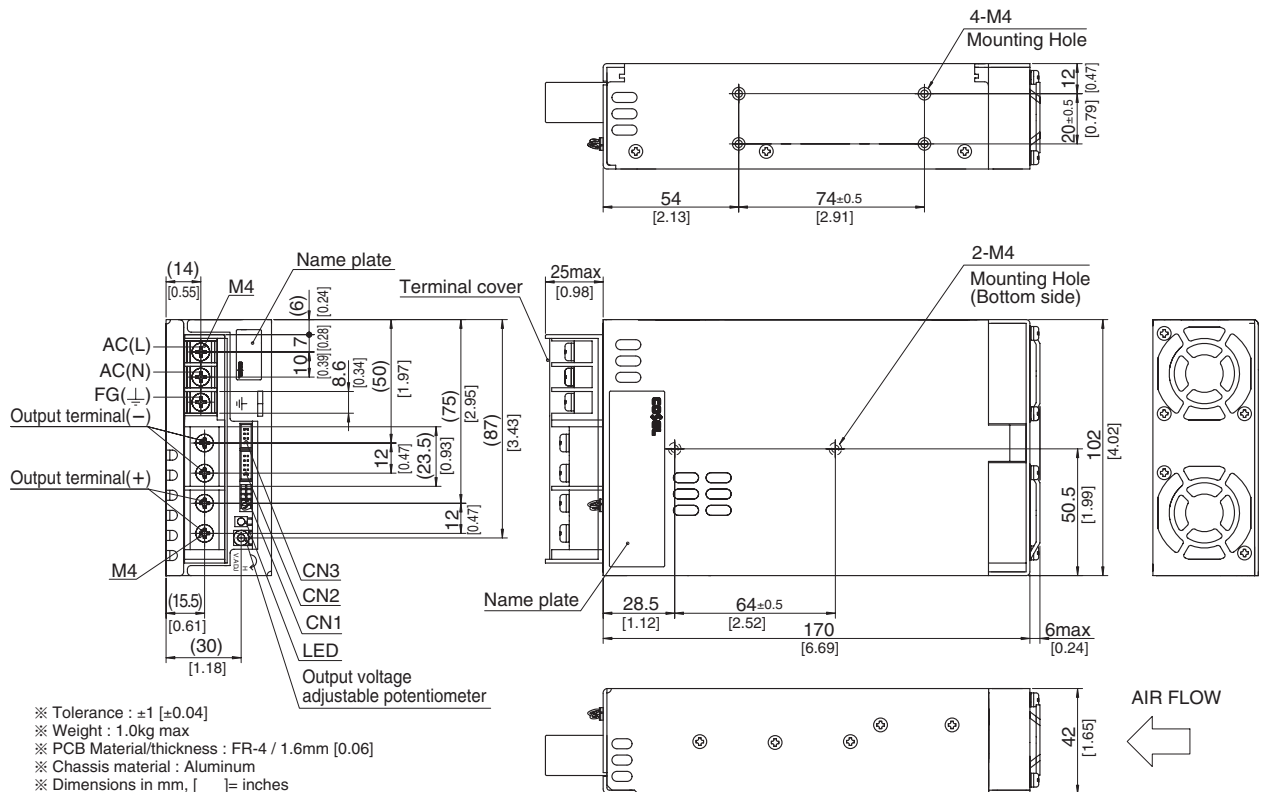

- ※ Tolerance : ±1 [±0.04]
- ※ Weight : 1.0kg max
- ※ PCB Material/thickness : FR-4 / 1.6mm [0.06]
- ※ Chassis material : Aluminum
- ※ Dimensions in mm, [ ] = inches
- ※ Mounting torque : 1.2N • m max
- ※ Screw tightening torque : 1.6N • m max
- ※ The housing for the remote sensing unused is mounted on CN1
- ※ Please connect safety ground to FG terminal on the unit.



# PBA600F

PB A 600 F -5 -□

① ② ③ ④ ⑤ ⑥

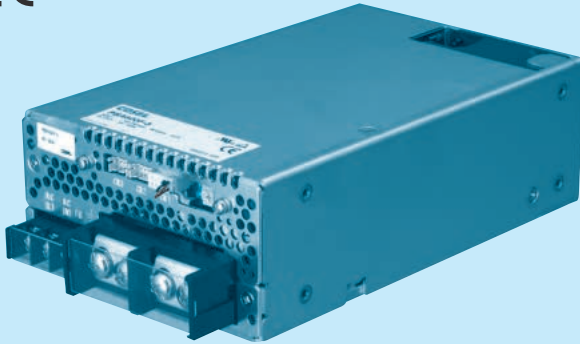
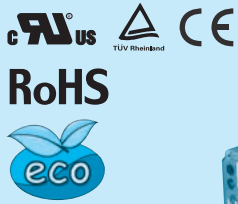

Example recommended EMI/EMC filter  
NAC-16-472



High voltage pulse noise type : NAP series  
Low leakage current type : NAM series  
\* A higher current rating EMI/EMC filter may be recommended in view of the other devices that could be connected in parallel with the power supply.

- ① Series name
- ② Single output
- ③ Output wattage
- ④ Universal input
- ⑤ Output voltage
- ⑥ Optional \*6
- C :with Coating
- G :Low leakage current
- U :Operation stop voltage is set at a lower value
- F1 :With Long-Life fan
- F3 :Reverse air exhaust type
- F4 :Low speed fan

Refer to instruction manual 7.1.

\*Make sure necessary tests will be carried out on your end equipment with the power supply installed in accordance with any required EMC/EMI regulations.

MODEL	PBA600F-3R3	PBA600F-5	PBA600F-7R5	PBA600F-12	PBA600F-15	PBA600F-24	PBA600F-36	PBA600F-48	
MAX OUTPUT WATTAGE[W]	396	600	600	636	645	648	648	624	
DC OUTPUT	ACIN 100V	3.3V 120A	5V 120A	7.5V 80A	12V 53A	15V 43A	24V 27A	36V 18A	48V 13A
	ACIN 200V *3	3.3V 120A	5V 120A	7.5V 80A	12V 53A	15V 43A	24V 27(31)A	36V 18A	48V 13A

## SPECIFICATIONS

MODEL	PBA600F-3R3	PBA600F-5	PBA600F-7R5	PBA600F-12	PBA600F-15	PBA600F-24	PBA600F-36	PBA600F-48		
INPUT	VOLTAGE[V] AC85 - 264 1φ or DC120 - 350 (AC50 or DC70 Please refer to the instruction manual 7. option *5)									
	CURRENT[A]	ACIN 100V	5.8typ	8.2typ						
		ACIN 200V	3typ	4.1typ						
	FREQUENCY[Hz] 50/60 (47 - 63)									
	EFFICIENCY[%]	ACIN 100V	70typ	75typ	76typ	79typ	79typ	81typ	82typ	81typ
		ACIN 200V	72typ	77typ	79typ	82typ	82typ	84typ	84typ	83typ
	POWER FACTOR	ACIN 100V	0.98typ (Io=100%)							
ACIN 200V		0.95typ (Io=100%)								
INRUSH CURRENT[A]	ACIN 100V	20/40typ (Io=100%) (Primary inrush current /Secondary inrush current) (More than 3 sec. to re-start)								
	ACIN 200V	40/40typ (Io=100%) (Primary inrush current /Secondary inrush current) (More than 3 sec. to re-start)								
LEAKAGE CURRENT[mA] 0.45/0.75max (ACIN 100V/240V 60Hz, Io=100%, According to IEC60950-1, DENAN)										
OUTPUT	VOLTAGE[V]	3.3	5	7.5	12	15	24	36	48	
	CURRENT[A]	ACIN 100V	120	120	80	53	43	27	18	13
		ACIN 200V *3	120	120	80	53	43	27(31)	18	13
	LINE REGULATION[mV] 20max									
	LOAD REGULATION[mV] 40max									
	RIPPLE[mVp-p]	0 to +50°C *1	80max	80max	120max	120max	120max	120max	150max	150max
		-20 - 0°C *1	140max	140max	160max	160max	160max	160max	160max	400max
	RIPPLE NOISE[mVp-p]	0 to +50°C *1	120max	120max	150max	150max	150max	150max	200max	200max
		-20 - 0°C *1	160max	160max	180max	180max	180max	180max	240max	500max
	TEMPERATURE REGULATION[mV]	0 to +50°C	40max	50max	75max	120max	150max	240max	360max	480max
		-20 to +50°C	60max	75max	120max	180max	180max	290max	440max	600max
	DRIFT [mV]	*2	12max	20max	30max	48max	60max	96max	144max	192max
	START-UP TIME[ms]	400typ(ACIN 100/200V, Io=100%) *Start-up time is 500ms typ for less than 1minute of applying input again from turning off the input voltage.								
HOLD-UP TIME[ms]	20typ (ACIN 100/200V, Io=100%)									
OUTPUT VOLTAGE ADJUSTMENT RANGE[V]	2.64 - 3.96	3.96 - 6.00	5.25 - 8.25	8.25 - 13.20	10.50 - 16.50	16.50 - 26.40	25.20 - 39.60	38.40 - 56.00		
OUTPUT VOLTAGE SETTING[V]	3.30 - 3.40	5.00 - 5.15	7.50 - 7.80	12.00 - 12.48	15.00 - 15.60	24.00 - 24.96	36.00 - 37.44	48.00 - 49.92		
PROTECTION CIRCUIT AND OTHERS	OVERCURRENT PROTECTION Works over 105% of rated current or 101% of peak current and recovers automatically									
	OVERVOLTAGE PROTECTION[V] *4	Vo+0.66 - 1.32	Vo+1.0 - 2.0	Vo+1.5 - 3.0	Vo+2.4 - 4.8	Vo+3.0 - 6.0	Vo+4.8 - 9.6	Vo+7.2 - 14.4	Vo+4.8 - 12.0	
	OPERATING INDICATION	LED (Green)								
	REMOTE SENSING	Provided								
REMOTE ON/OFF	Provided									
ISOLATION	INPUT-OUTPUT · RC	AC3.000V 1minute, Cutoff current = 10mA, DC500V 50MΩmin (At Room Temperature)								
	INPUT-FG	AC2.000V 1minute, Cutoff current = 10mA, DC500V 50MΩmin (At Room Temperature)								
	OUTPUT · RC · AUX-FG	AC500V 1minute, Cutoff current = 100mA, DC500V 50MΩmin (At Room Temperature)								
	OUTPUT-RC · AUX	AC500V 1minute, Cutoff current = 100mA, DC500V 50MΩmin (At Room Temperature)								
ENVIRONMENT	OPERATING TEMP.,HUMID.AND ALTITUDE	-20 to +71°C (Refer to "Derating"), 20 - 90%RH (Non condensing) 3,000m (10,000feet) max								
	STORAGE TEMP.,HUMID.AND ALTITUDE	-20 to +75°C, 20 - 90%RH (Non condensing) 9,000m (30,000feet) max								
	VIBRATION	10 - 55Hz, 19.6m/s <sup>2</sup> (2G), 3minutes period, 60minutes each along X, Y and Z axis								
IMPACT	196.1m/s <sup>2</sup> (20G), 11ms, once each X, Y and Z axis									
SAFETY AND NOISE REGULATIONS	AGENCY APPROVALS (At only AC input)	UL60950-1, C-UL(CSA60950-1), EN60950-1, EN50178 Complies with DEN-AN								
	CONDUCTED NOISE	Complies with FCC Part15 classB, VCCI-B, CISPR22-B, EN55011-B, EN55022-B								
	HARMONIC ATTENUATOR	Complies with IEC61000-3-2 *7								
OTHERS	CASE SIZE/WEIGHT	120×61×190mm [4.72×2.4×7.48 inches] (without terminal block and screw) (W×H×D) /1.6kg max								
	COOLING METHOD	Forced cooling (internal fan)								

\*1 Measured by 20MHz oscilloscope or Ripple-Noise meter(equivalent to KEISOKU-GIKEN :RM101).  
 \*2 Drift is the change in DC output for an eight hour period after a half-hour warm-up at 25°C.  
 \*3 () means peak current. Peak loading for 10s. And Duty 35% max, refer to Instruction manual in detail.  
 \*4 Overvoltage protection circuit to follow to output voltage setting. Standard overvoltage protection circuit is please contact us for details.

\*5 Derating is required.Consult us for details.  
 \*6 Please contact us about safety approvals for the model with option.  
 \*7 Please contact us about class C.  
 \* A sound may occur from power supply at pulse loading.



## Block diagram

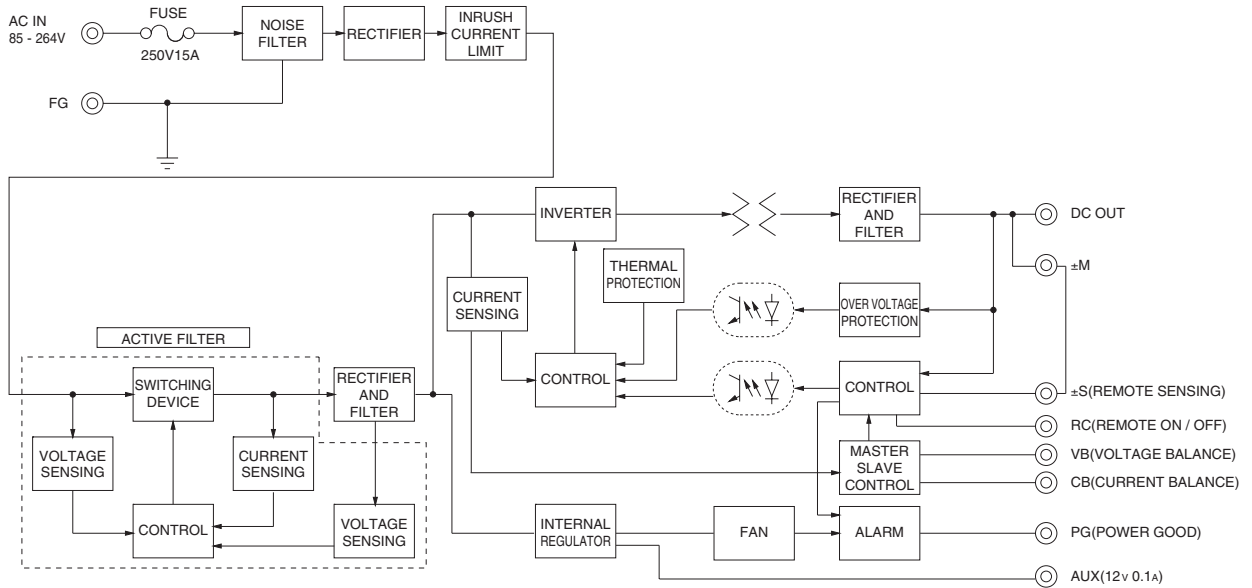

## External view

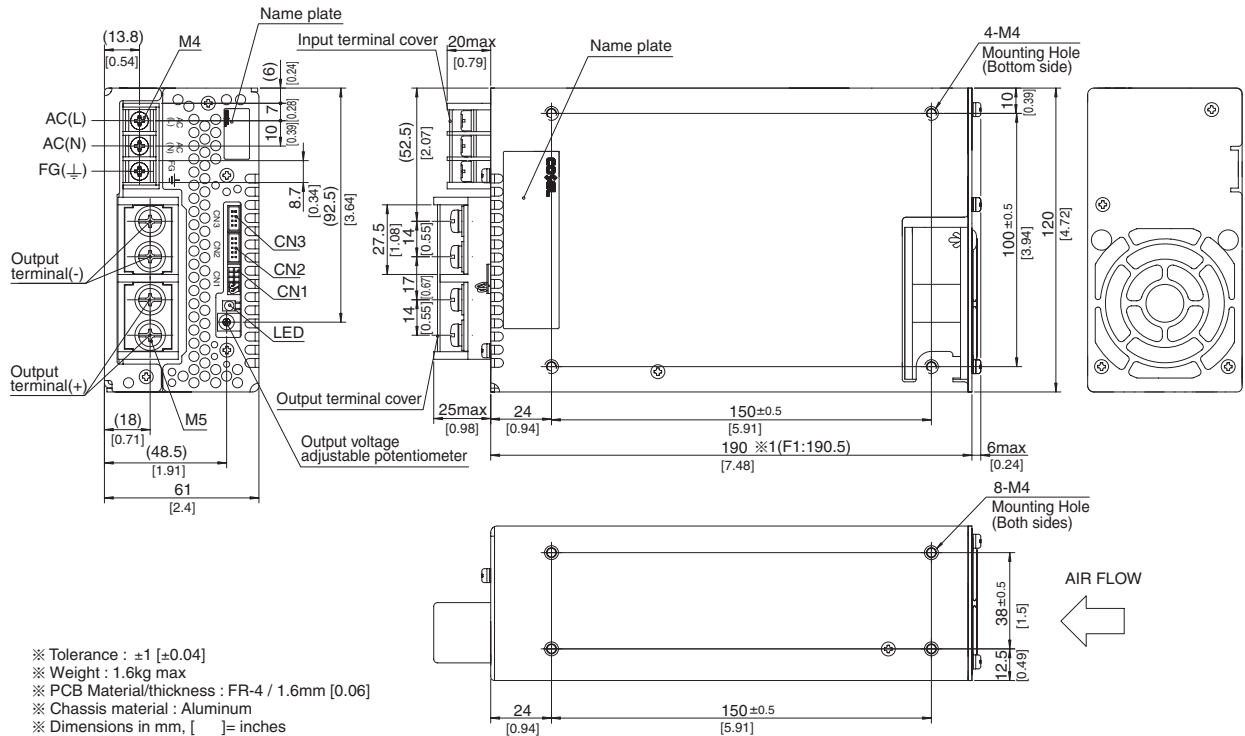

- ※ Tolerance : ±1 [±0.04]
- ※ Weight : 1.6kg max
- ※ PCB Material/thickness : FR-4 / 1.6mm [0.06]
- ※ Chassis material : Aluminum
- ※ Dimensions in mm, [ ] = inches
- ※ Mounting torque : 1.2N · m (12.8kgf · cm) max
- ※ Screw tightening torque : M4 1.6N · m (16.9kgf · cm) max  
M5 2.5N · m (24.5kgf · cm) max
- ※ The housing for the remote sensing unused is mounted on CN1
- ※ 1 F1(Optional):190.5
- ※ Please connect safety ground to FG terminal on the unit.



# PBA1000F

**PB A 1000 F -5 -□**

① ② ③ ④ ⑤ ⑥

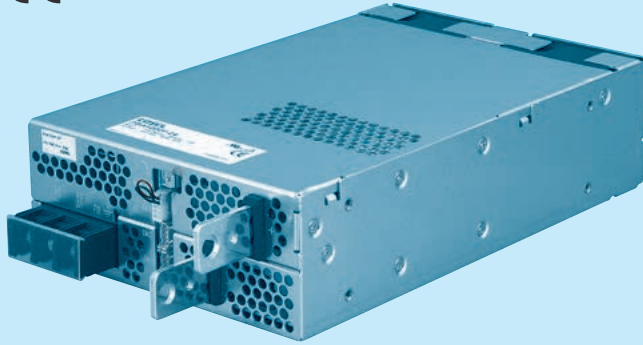
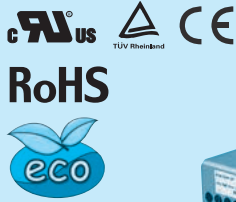

Example recommended EMI/EMC filter  
**NAC-20-472**



High voltage pulse noise type : NAP series  
Low leakage current type : NAM series  
\* A higher current rating EMI/EMC filter may be recommended in view of the other devices that could be connected in parallel with the power supply.

- ① Series name
- ② Single output
- ③ Output wattage
- ④ Universal input
- ⑤ Output voltage
- ⑥ Optional \*6
- C :with Coating
- G :Low leakage current
- U :Operation stop voltage is set at a lower value
- F1 :With Long-Life fan
- F3 :Reverse air exhaust type
- F4 :Low speed fan

Refer to instruction manual 7.1.

\*Make sure necessary tests will be carried out on your end equipment with the power supply installed in accordance with any required EMC/EMI regulations.

MODEL	PBA1000F-3R3	PBA1000F-5	PBA1000F-7R5	PBA1000F-12	PBA1000F-15	PBA1000F-24	PBA1000F-36	PBA1000F-48	
MAX OUTPUT WATTAGE[W]	660	1000	1005	1056	1050	1056	1044	1056	
DC OUTPUT	ACIN 100V	3.3V 200A	5V 200A	7.5V 134A	12V 88A	15V 70A	24V 44A	36V 29A	48V 22A
	ACIN 200V *3	3.3V 200A	5V 200A	7.5V 134A	12V 88A	15V 70A	24V 44(51)A	36V 29A	48V 22A

## SPECIFICATIONS

MODEL	PBA1000F-3R3	PBA1000F-5	PBA1000F-7R5	PBA1000F-12	PBA1000F-15	PBA1000F-24	PBA1000F-36	PBA1000F-48
<b>INPUT</b>	<b>VOLTAGE[V]</b> AC85 - 264 1 φ or DC120 - 350 (AC50 or DC70 Please refer to the instruction manual 7. option *5) <b>CURRENT[A]</b> ACIN 100V 9typ 13typ ACIN 200V 5typ 7typ <b>FREQUENCY[Hz]</b> 50/60 (47 - 63) <b>EFFICIENCY[%]</b> ACIN 100V 74typ 79typ 80typ 82typ 82typ 84typ 84typ 84typ ACIN 200V 76typ 81typ 83typ 84typ 84typ 86typ 86typ 86typ <b>POWER FACTOR</b> ACIN 100V 0.98typ (Io=100%) ACIN 200V 0.95typ (Io=100%) <b>INRUSH CURRENT[A]</b> ACIN 100V 20/40typ (Io=100%) (Primary inrush current /Secondary inrush current) (More than 10 sec. to re-start) ACIN 200V 40/40typ (Io=100%) (Primary inrush current /Secondary inrush current) (More than 10 sec. to re-start) <b>LEAKAGE CURRENT[mA]</b> 0.5/1.0max (ACIN 100V/240V 60Hz, Io=100%, According to IEC60950-1, DENAN)							
<b>OUTPUT</b>	<b>VOLTAGE[V]</b> 3.3 5 7.5 12 15 24 36 48 <b>CURRENT[A]</b> ACIN 100V 200 200 134 88 70 44 29 22 ACIN 200V *3 200 200 134 88 70 44(51) 29 22 <b>LINE REGULATION[mV]</b> 20max 20max 36max 48max 60max 96max 144max 192max <b>LOAD REGULATION[mV]</b> 40max 40max 60max 100max 120max 150max 150max 300max <b>RIPPLE[mVp-p]</b> 0 to +50°C *1 80max 80max 120max 120max 120max 120max 150max 150max -20 - 0°C *1 140max 140max 160max 160max 160max 160max 160max 400max <b>RIPPLE NOISE[mVp-p]</b> 0 to +50°C *1 120max 120max 150max 150max 150max 150max 200max 200max -20 - 0°C *1 160max 160max 180max 180max 180max 180max 240max 500max <b>TEMPERATURE REGULATION[mV]</b> 0 to +50°C 40max 50max 75max 120max 150max 240max 360max 480max -20 to +50°C 60max 75max 120max 180max 180max 290max 440max 600max <b>DRIFT[mV]</b> *2 12max 20max 30max 48max 60max 96max 144max 192max <b>START-UP TIME[ms]</b> 400typ(ACIN 100/200V, Io=100%) *Start-up time is 500ms typ for less than 1minute of applying input again from turning off the input voltage. <b>HOLD-UP TIME[ms]</b> 20typ (ACIN 100/200V, Io=100%) <b>OUTPUT VOLTAGE ADJUSTMENT RANGE[V]</b> 2.64 - 3.96 3.96 - 6.00 5.25 - 8.25 8.25 - 13.20 10.50 - 16.50 16.50 - 26.40 25.20 - 39.60 38.40 - 56.00 <b>OUTPUT VOLTAGE SETTING[V]</b> 3.30 - 3.40 5.00 - 5.15 7.50 - 7.80 12.00 - 12.48 15.00 - 15.60 24.00 - 24.96 36.00 - 37.44 48.00 - 49.92							
<b>PROTECTION CIRCUIT AND OTHERS</b>	<b>OVERCURRENT PROTECTION</b> Works over 105% of rated current or 101% of peak current and recovers automatically <b>OVERVOLTAGE PROTECTION[V] *4</b> Vo+0.66 - 1.32 Vo+1.0 - 2.0 Vo+1.5 - 3.0 Vo+2.4 - 4.8 Vo+3.0 - 6.0 Vo+4.8 - 9.6 Vo+7.2 - 14.4 Vo+4.8 - 12.0 <b>OPERATING INDICATION</b> LED (Green) <b>REMOTE SENSING</b> Provided <b>REMOTE ON/OFF</b> Provided							
<b>ISOLATION</b>	<b>INPUT-OUTPUT · RC</b> AC3.000V 1minute, Cutoff current = 25mA, DC500V 50MΩmin (At Room Temperature) <b>INPUT-FG</b> AC2.000V 1minute, Cutoff current = 25mA, DC500V 50MΩmin (At Room Temperature) <b>OUTPUT · RC · AUX-FG</b> AC500V 1minute, Cutoff current = 100mA, DC500V 50MΩmin (At Room Temperature) <b>OUTPUT-RC · AUX</b> AC500V 1minute, Cutoff current = 100mA, DC500V 50MΩmin (At Room Temperature)							
<b>ENVIRONMENT</b>	<b>OPERATING TEMP.,HUMID.AND ALTITUDE</b> -20 to +71°C (Refer to "Derating"), 20 - 90%RH (Non condensing) 3,000m (10,000feet) max <b>STORAGE TEMP.,HUMID.AND ALTITUDE</b> -20 to +75°C, 20 - 90%RH (Non condensing) 9,000m (30,000feet) max <b>VIBRATION</b> 10 - 55Hz, 19.6m/s <sup>2</sup> (2G), 3minutes period, 60minutes each along X, Y and Z axis <b>IMPACT</b> 196.1m/s <sup>2</sup> (20G), 11ms, once each X, Y and Z axis							
<b>SAFETY AND NOISE REGULATIONS</b>	<b>AGENCY APPROVALS (At only AC input)</b> UL60950-1, C-UL(CSA60950-1), EN60950-1, EN50178 Complies with DEN-AN <b>CONDUCTED NOISE</b> Complies with FCC Part15 classB, VCCI-B, CISPR22-B, EN55011-B, EN55022-B <b>HARMONIC ATTENUATOR</b> Complies with IEC61000-3-2 *7							
<b>OTHERS</b>	<b>CASE SIZE/WEIGHT</b> 150×61×240mm [5.91×2.4×9.45 inches] (without terminal block and screw) (W×H×D) /2.2kg max <b>COOLING METHOD</b> Forced cooling (internal fan)							

\*1 Measured by 20MHz oscilloscope or Ripple-Noise meter(equivalent to KEISOKU-GIKEN :RM101).  
Ripple and ripple noise is measured on measuring board with capacitor of 22 μF within 150mm from the output terminal.  
\*2 Drift is the change in DC output for an eight hour period after a half-hour warm-up at 25°C.  
\*3 () means peak current. Peak loading for 10s. And Duty 35% max, refer to Instruction manual in detail.

\*4 Overvoltage protection circuit to follow to output voltage setting. Standard overvoltage protection circuit is please contact us for details.  
\*5 Derating is required. Consult us for details.  
\*6 Please contact us about safety approvals for the model with option.  
\*7 Please contact us about class C.  
\* A sound may occur from power supply at pulse loading.

## Block diagram

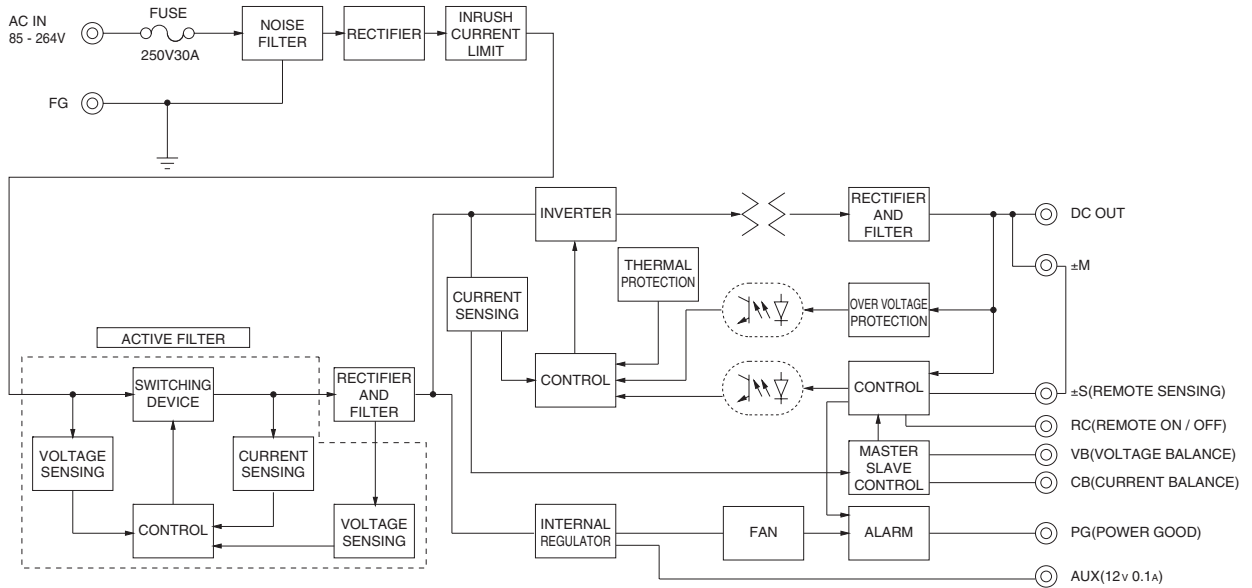

## External view

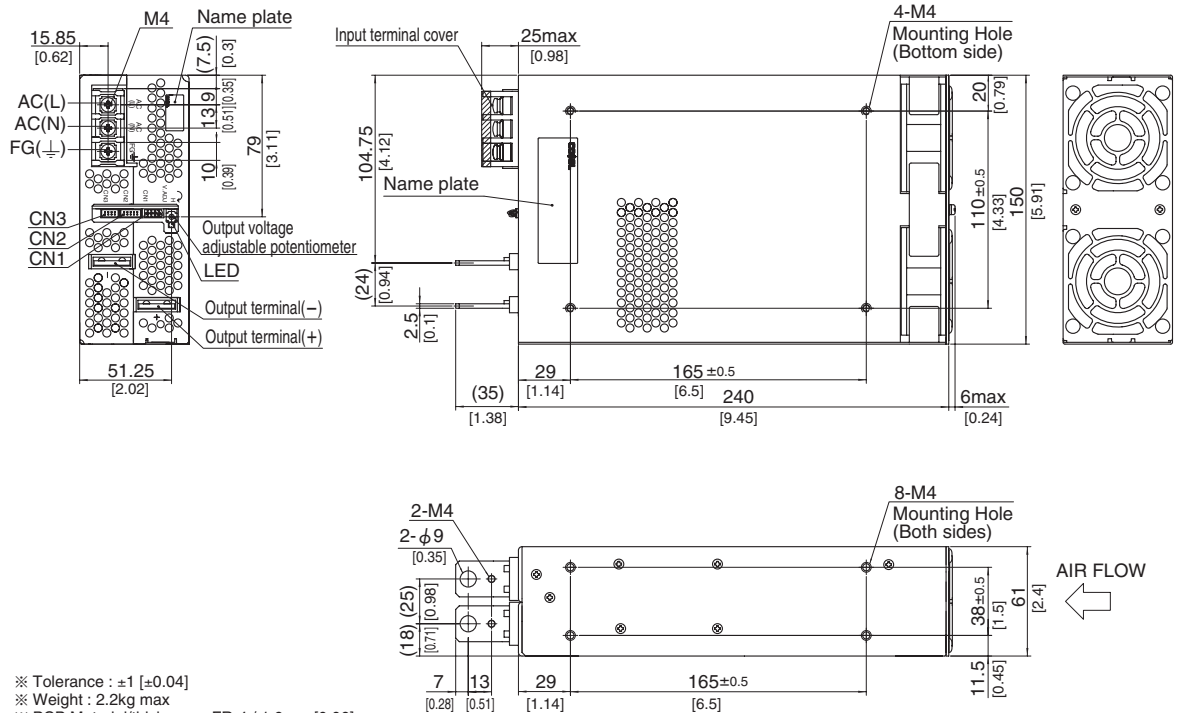

- ※ Tolerance : ±1 [±0.04]
- ※ Weight : 2.2kg max
- ※ PCB Material/thickness : FR-4 / 1.6mm [0.06]
- ※ Chassis material : Aluminum
- ※ Dimensions in mm, [ ] = inches
- ※ Mounting torque : 1.2N · m (12.8kgf · cm) max
- ※ Screw tightening torque : 1.6N · m (16.9kgf · cm) max
- ※ The housing for the remote sensing unused is mounted on CN1
- ※ Please connect safety ground to FG terminal on the unit.

# PBA1500F

**PB A 1500 F -5 -□**

① ② ③ ④ ⑤ ⑥

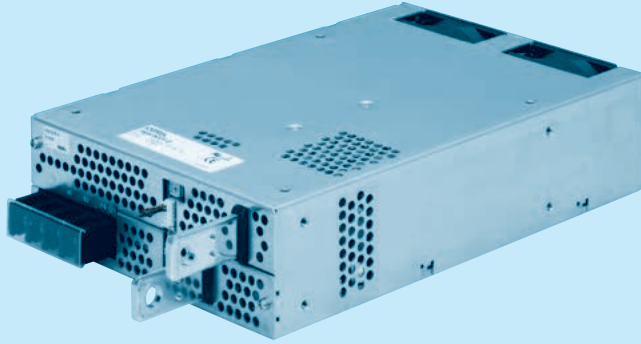
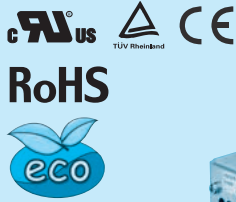

Example recommended EMI/EMC filter  
**NAC-20-472**



High voltage pulse noise type : NAP series  
Low leakage current type : NAM series  
\* A higher current rating EMI/EMC filter may be recommended in view of the other devices that could be connected in parallel with the power supply.

- ① Series name
- ② Single output
- ③ Output wattage
- ④ Universal input
- ⑤ Output voltage
- ⑥ Optional \*6
- C : with Coating
- G : Low leakage current
- U : Operation stop voltage is set at a lower value
- F1 : With Long-Life fan
- F3 : Reverse air exhaust type
- F4 : Low speed fan

Refer to instruction manual 7.1.

\*Make sure necessary tests will be carried out on your end equipment with the power supply installed in accordance with any required EMC/EMI regulations.

MODEL	PBA1500F-3R3	PBA1500F-5	PBA1500F-7R5	PBA1500F-12	PBA1500F-15	PBA1500F-24	PBA1500F-36	PBA1500F-48	
MAX OUTPUT WATTAGE[W]	990	1500	1500	1500	1500	1680	1692	1680	
DC OUTPUT	ACIN 100V	3.3V 300A	5V 300A	7.5V 200A	12V 125A	15V 100A	24V 65A	36V 42A	48V 32A
	ACIN 200V *3	3.3V 300A	5V 300A	7.5V 200A	12V 125A	15V 100A	24V 70(105)A	36V 47(70)A	48V 35A

## SPECIFICATIONS

	MODEL	PBA1500F-3R3	PBA1500F-5	PBA1500F-7R5	PBA1500F-12	PBA1500F-15	PBA1500F-24	PBA1500F-36	PBA1500F-48	
INPUT	VOLTAGE[V]	AC85 - 264 1φ or DC120 - 370 (AC50 or DC70 Please refer to the instruction manual 7. option *5)								
	CURRENT[A]	ACIN 100V	15typ	19typ						
		ACIN 200V	8typ	10typ						
	FREQUENCY[Hz]	50/60 (47 - 63)								
	EFFICIENCY[%]	ACIN 100V	72typ	77typ	81typ	81typ	83typ	84typ	84typ	84typ
		ACIN 200V	75typ	81typ	83typ	84typ	86typ	87typ	87typ	87typ
	POWER FACTOR	ACIN 100V	0.98typ (Io=100%)							
ACIN 200V		0.95typ (Io=100%)								
INRUSH CURRENT[A]	ACIN 100V	20/40typ (Io=100%) (Primary inrush current /Secondary inrush current) (More than 10 sec. to re-start)								
	ACIN 200V	40/40typ (Io=100%) (Primary inrush current /Secondary inrush current) (More than 10 sec. to re-start)								
LEAKAGE CURRENT[mA]	0.9/1.5max (ACIN 100V/240V 60Hz, Io=100%, According to IEC60950-1, DENAN)									
OUTPUT	VOLTAGE[V]	3.3	5	7.5	12	15	24	36	48	
	CURRENT[A]	ACIN 100V	300	300	200	125	100	65	42	32
		ACIN 200V *3	300	300	200	125	100	70(105)	47(70)	35
	LINE REGULATION[mV]	20max	20max	36max	48max	60max	96max	144max	192max	
	LOAD REGULATION[mV]	40max	40max	60max	100max	120max	150max	150max	300max	
	RIPPLE[mVp-p]	0 to +50°C *1	80max	80max	120max	120max	120max	120max	150max	150max
		-20 - 0°C *1	140max	140max	160max	160max	160max	160max	160max	400max
	RIPPLE NOISE[mVp-p]	0 to +50°C *1	120max	120max	150max	150max	150max	150max	200max	200max
		-20 - 0°C *1	160max	160max	180max	180max	180max	180max	240max	500max
	TEMPERATURE REGULATION[mV]	0 to +50°C	40max	50max	75max	120max	150max	240max	360max	480max
		-20 to +50°C	60max	75max	120max	180max	180max	290max	440max	600max
	DRIFT[mV]	*2	12max	20max	30max	48max	60max	96max	144max	192max
	START-UP TIME[ms]	600typ(ACIN 100/200V, Io=100%)								
HOLD-UP TIME[ms]	20typ (ACIN 100/200V, Io=100%)									
OUTPUT VOLTAGE ADJUSTMENT RANGE[V]	2.64 - 3.96	3.96 - 6.00	5.25 - 8.25	8.25 - 13.20	10.50 - 16.50	16.50 - 26.40	25.20 - 39.60	38.40 - 56.00		
OUTPUT VOLTAGE SETTING[V]	3.30 - 3.40	5.00 - 5.15	7.50 - 7.80	12.00 - 12.48	15.00 - 15.60	24.00 - 24.96	36.00 - 37.44	48.00 - 49.92		
PROTECTION CIRCUIT AND OTHERS	OVERCURRENT PROTECTION	Works over 105% of rated current or 101% of peak current and recovers automatically								
	OVERVOLTAGE PROTECTION[V] *4	Vo+0.66 - 1.32	Vo+1.0 - 2.0	Vo+1.5 - 3.0	Vo+2.4 - 4.8	Vo+3.0 - 6.0	Vo+4.8 - 9.6	Vo+7.2 - 14.4	Vo+4.8 - 12.0	
	OPERATING INDICATION	LED (Green)								
	REMOTE SENSING	Provided								
ISOLATION	REMOTE ON/OFF	Provided								
	INPUT-OUTPUT · RC	AC3.000V 1minute, Cutoff current = 25mA, DC500V 50MΩmin (At Room Temperature)								
	INPUT-FG	AC2.000V 1minute, Cutoff current = 25mA, DC500V 50MΩmin (At Room Temperature)								
	OUTPUT · RC · AUX-FG	AC500V 1minute, Cutoff current = 100mA, DC500V 50MΩmin (At Room Temperature)								
ENVIRONMENT	OUTPUT-RC · AUX	AC500V 1minute, Cutoff current = 100mA, DC500V 50MΩmin (At Room Temperature)								
	OPERATING TEMP.,HUMID.AND ALTITUDE	-20 to +71°C (Refer to "Derating"), 20 - 90%RH (Non condensing) 3,000m (10,000feet) max								
	STORAGE TEMP.,HUMID.AND ALTITUDE	-20 to +75°C, 20 - 90%RH (Non condensing) 9,000m (30,000feet) max								
	VIBRATION	10 - 55Hz, 19.6m/s <sup>2</sup> (2G), 3minutes period, 60minutes each along X, Y and Z axis								
SAFETY AND NOISE REGULATIONS	IMPACT	196.1m/s <sup>2</sup> (20G), 11ms, once each X, Y and Z axis								
	AGENCY APPROVALS (At only AC input)	UL60950-1, C-UL(CSA60950-1), EN60950-1, EN50178 Complies with DEN-AN								
	CONDUCTED NOISE	Complies with FCC Part15 classB, VCCI-B, CISPR22-B, EN55011-B, EN55022-B, additional EMI/EMC Filter required for meeting class B								
	HARMONIC ATTENUATOR	Complies with IEC61000-3-2 *7								
OTHERS	CASE SIZE/WEIGHT	178×61×268mm [7.01×2.4×10.55 inches] (without terminal block and screw) (W×H×D) /3.4kg max								
	COOLING METHOD	Forced cooling (internal fan)								

\*1 Measured by 20MHz oscilloscope or Ripple-Noise meter(equivalent to KEISOKU-GIKEN :RM101).  
Ripple and ripple noise is measured on measuring board with capacitor of 22 μF within 150mm from the output terminal.  
\*2 Drift is the change in DC output for an eight hour period after a half-hour warm-up at 25°C.  
\*3 () means peak current. Peak loading for 10s. And Duty 35% max, refer to Instruction manual in detail.

\*4 Overvoltage protection circuit to follow to output voltage setting. Standard overvoltage protection circuit is please contact us for details.  
\*5 Derating is required. Consult us for details.  
\*6 Please contact us about safety approvals for the model with option.  
\*7 Please contact us about class C.  
\* A sound may occur from power supply at pulse loading.

## Block diagram

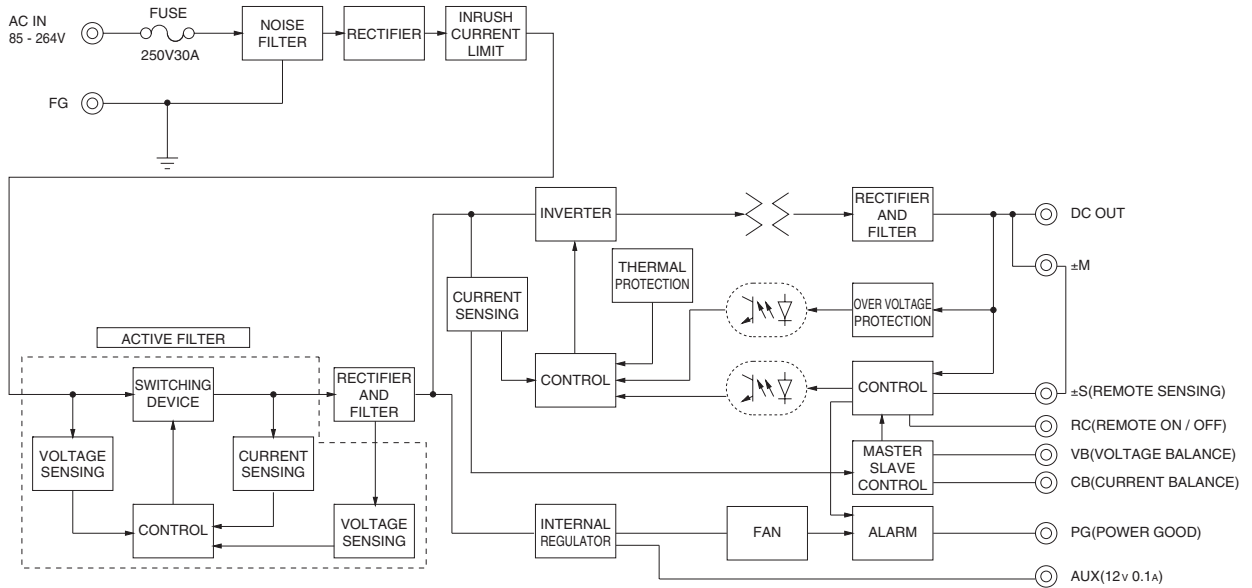

## External view

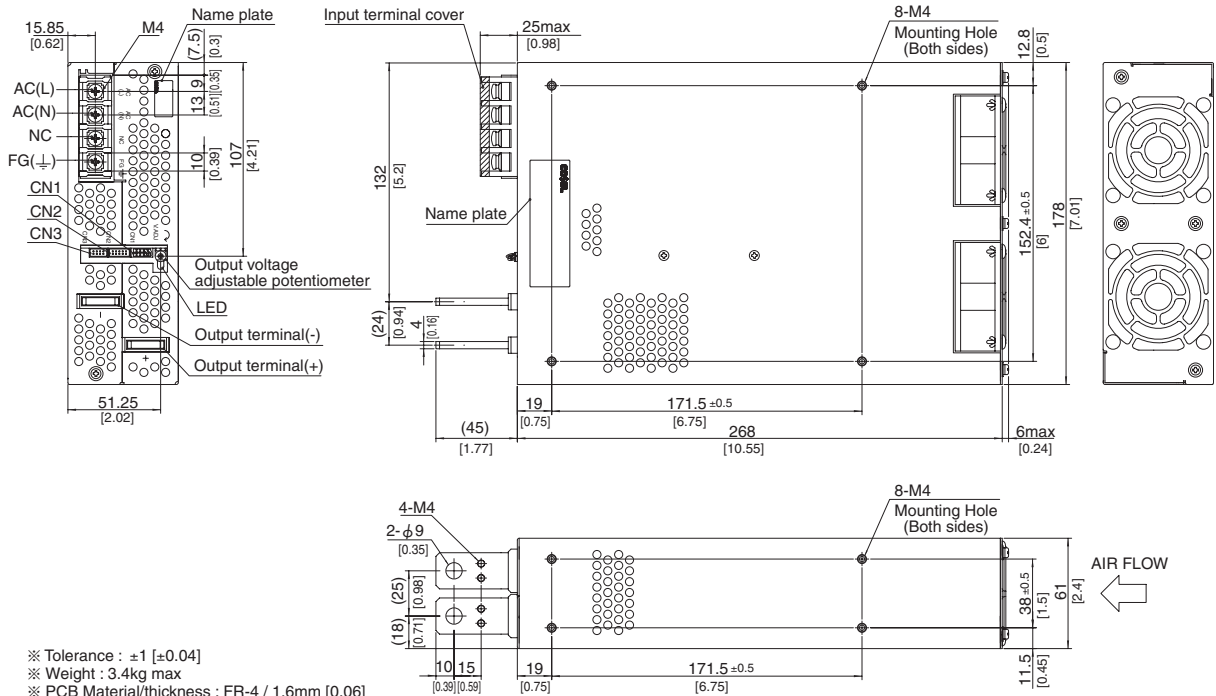

- ※ Tolerance :  $\pm 1$  [ $\pm 0.04$ ]
- ※ Weight : 3.4kg max
- ※ PCB Material/thickness : FR-4 / 1.6mm [0.06]
- ※ Chassis material : Aluminum
- ※ Dimensions in mm, [ ] = inches
- ※ Mounting torque :  $1.2N \cdot m$  (12.8kgf  $\cdot$  cm) max
- ※ Screw tightening torque :  $1.6N \cdot m$  (16.9kgf  $\cdot$  cm) max
- ※ The housing for the remote sensing unused is mounted on CN1
- ※ Please connect safety ground to FG terminal on the unit.

# PBA1500T

PB A 1500 T -5 -□

① ② ③ ④ ⑤ ⑥

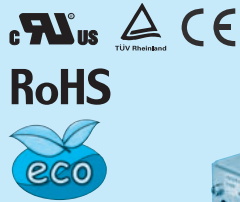

Example recommended EMI/EMC filter  
TAC-10-683

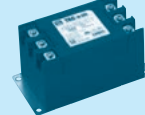

\* A higher current rating EMI/EMC filter may be recommended in view of the other devices that could be connected in parallel with the power supply.

- ① Series name
- ② Single output
- ③ Output wattage
- ④ Triple input phase
- ⑤ Output voltage
- ⑥ Optional \*6
- C :with Coating
- G :Low leakage current
- U :Operation stop voltage is set at a lower value
- F1 :With Long-Life fan
- F3 :Reverse air exhaust type
- F4 :Low speed fan

Refer to instruction manual 7.1.

\*Make sure necessary tests will be carried out on your end equipment with the power supply installed in accordance with any required EMC/EMI regulations.

MODEL	PBA1500T-5	PBA1500T-12	PBA1500T-24	PBA1500T-48
MAX OUTPUT WATTAGE[W]	1500	1500	1680	1680
DC OUTPUT	ACIN 200V *3 5V 300A	12V 125A	24V 70(105)A	48V 35A

## SPECIFICATIONS

	MODEL	PBA1500T-5	PBA1500T-12	PBA1500T-24	PBA1500T-48	
INPUT	VOLTAGE[V]	AC170 - 264 3φ (AC100 Please refer to the instruction manual 7. option *5)				
	CURRENT[A]	ACIN 200V 6typ				
	FREQUENCY[Hz]	50/60 (47 - 63)				
	EFFICIENCY[%]	ACIN 200V 81typ	84typ	87typ	87typ	
	POWER FACTOR	ACIN 200V 0.95typ (Io=100%)				
	INRUSH CURRENT[A]	ACIN 200V 40/40typ (Io=100%) (Primary inrush current /Secondary inrush current) (More than 10 sec. to re-start)				
OUTPUT	LEAKAGE CURRENT[mA]	1.5max (ACIN 240V 60Hz, Io=100%, According to IEC60950-1, DENAN)				
	VOLTAGE[V]	5	12	24	48	
	CURRENT[A]	ACIN 200V *3 300	125	70(105)	35	
	LINE REGULATION[mV]	20max	48max	96max	192max	
	LOAD REGULATION[mV]	40max	100max	150max	300max	
	RIPPLE[mVp-p]	0 to +50°C *1	80max	120max	120max	150max
		-20 - 0°C *1	140max	160max	160max	400max
	RIPPLE NOISE[mVp-p]	0 to +50°C *1	120max	150max	150max	200max
		-20 - 0°C *1	160max	180max	180max	500max
	TEMPERATURE REGULATION[mV]	0 to +50°C	50max	120max	240max	480max
		-20 to +50°C	75max	180max	290max	600max
	DRIFT[mV]	*2 20max	48max	96max	192max	
START-UP TIME[ms]	300typ(ACIN 200V, Io=100%) * Start-up time is 500ms typ for less than 1 minute of applying input again from turning off the input voltage.					
HOLD-UP TIME[ms]	20typ (ACIN 200V, Io=100%)					
OUTPUT VOLTAGE ADJUSTMENT RANGE[V]	3.96 - 6.00	8.25 - 13.20	16.50 - 26.40	38.40 - 56.00		
OUTPUT VOLTAGE SETTING[V]	5.00 - 5.15	12.00 - 12.48	24.00 - 24.96	48.00 - 49.92		
PROTECTION CIRCUIT AND OTHERS	OVERCURRENT PROTECTION	Works over 105% of rated current or 101% of peak current and recovers automatically				
	OVERVOLTAGE PROTECTION[V] *4	Vo+1.0 - 2.0	Vo+2.4 - 4.8	Vo+4.8 - 9.6	Vo+2.0 - 12.0	
	OPERATING INDICATION	LED (Green)				
	REMOTE SENSING	Provided				
ISOLATION	REMOTE ON/OFF	Provided				
	INPUT-OUTPUT · RC	AC3,000V 1minute, Cutoff current = 25mA, DC500V 50MΩmin (At Room Temperature)				
	INPUT-FG	AC2,000V 1minute, Cutoff current = 25mA, DC500V 50MΩmin (At Room Temperature)				
	OUTPUT · RC · AUX-FG	AC500V 1minute, Cutoff current = 100mA, DC500V 50MΩmin (At Room Temperature)				
ENVIRONMENT	OUTPUT-RC · AUX	AC500V 1minute, Cutoff current = 100mA, DC500V 50MΩmin (At Room Temperature)				
	OPERATING TEMP.,HUMID.AND ALTITUDE	-20 to +71°C (Refer to "Derating"), 20 - 90%RH (Non condensing) 3,000m (10,000feet) max				
	STORAGE TEMP.,HUMID.AND ALTITUDE	-20 to +75°C, 20 - 90%RH (Non condensing) 9,000m (30,000feet) max				
	VIBRATION	10 - 55Hz, 19.6m/s <sup>2</sup> (2G), 3minutes period, 60minutes each along X, Y and Z axis				
SAFETY AND NOISE REGULATIONS	IMPACT	196.1m/s <sup>2</sup> (20G), 11ms, once each X, Y and Z axis				
	AGENCY APPROVALS (At only AC input)	UL60950-1, C-UL(CSA60950-1), EN60950-1, EN50178 Complies with DEN-AN				
	CONDUCTED NOISE	Complies with FCC Part15 classB, VCCI-B, CISPR22-B, EN50111-B, EN55022-B, additional EMI/EMC Filter required for meeting class B				
OTHERS	CASE SIZE/WEIGHT	178×61×268mm [7.01×2.4×10.55 inches] (without terminal block and screw) (W×H×D) /3.4kg max				
	COOLING METHOD	Forced cooling (internal fan)				

\*1 Measured by 20MHz oscilloscope or Ripple-Noise meter(equivalent to KEISOKU-GIKEN :RM101).  
Ripple and ripple noise is measured on measuring board with capacitor of 22 μF within 150mm from the output terminal.  
\*2 Drift is the change in DC output for an eight hour period after a half-hour warm-up at 25°C.  
\*3 () means peak current. Peak loading for 10s. And Duty 35% max, refer to Instruction manual in detail.

\*4 Overvoltage protection circuit to follow to output voltage setting. Standard overvoltage protection circuit is please contact us for details.  
\*5 Derating is required. Consult us for details.  
\*6 Please contact us about safety approvals for the model with option.  
\* A sound may occur from power supply at pulse loading.



## Block diagram

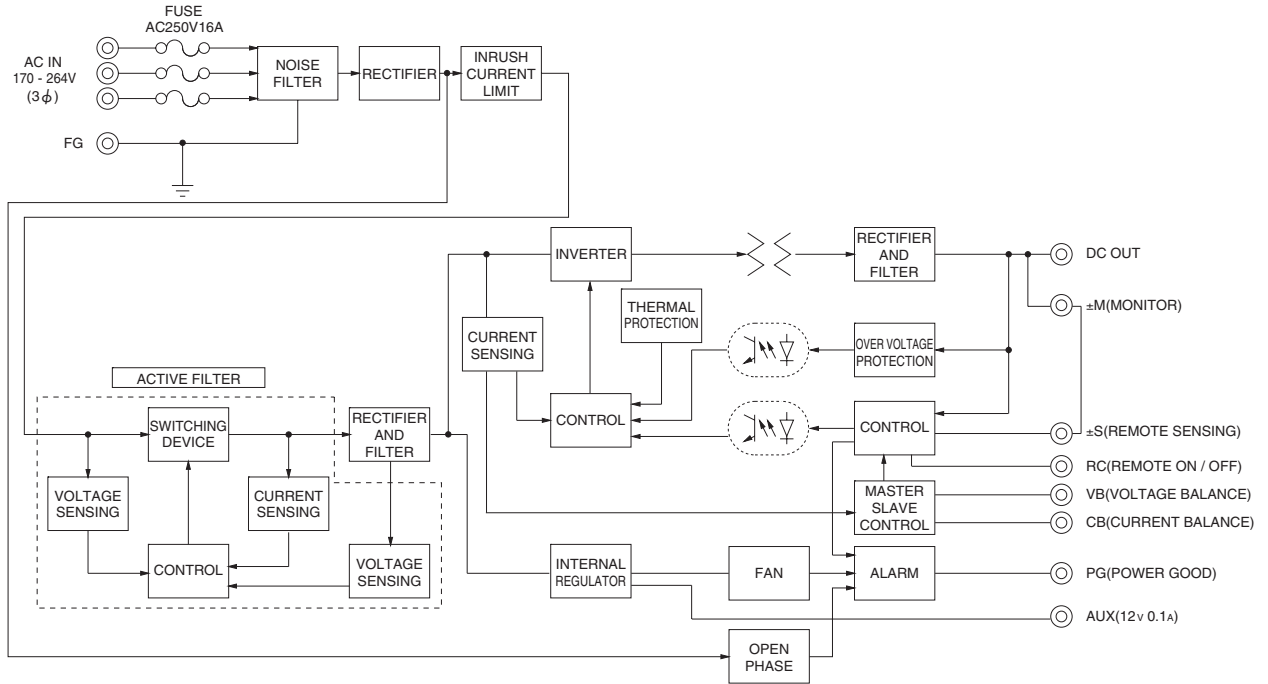

## External view

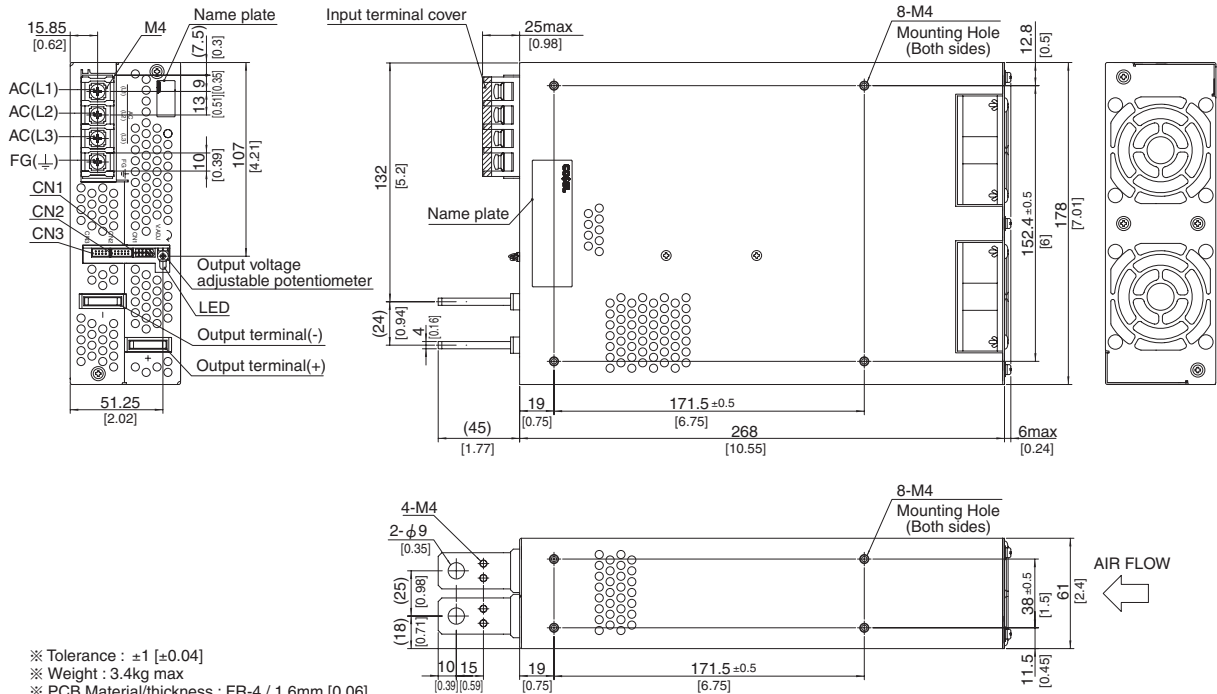

- ※ Tolerance :  $\pm 1$  [ $\pm 0.04$ ]
- ※ Weight : 3.4kg max
- ※ PCB Material/thickness : FR-4 / 1.6mm [0.06]
- ※ Chassis material : Aluminum
- ※ Dimensions in mm, [ ] = inches
- ※ Mounting torque :  $1.2\text{N} \cdot \text{m}$  ( $12.8\text{kgf} \cdot \text{cm}$ ) max
- ※ Screw tightening torque :  $1.6\text{N} \cdot \text{m}$  ( $16.9\text{kgf} \cdot \text{cm}$ ) max
- ※ The housing for the remote sensing unused is mounted on CN1
- ※ Please connect safety ground to unit in M4 holes.



# PBW15F

PB W 15 F - □ - □  
 ① ② ③ ④ ⑤ ⑥

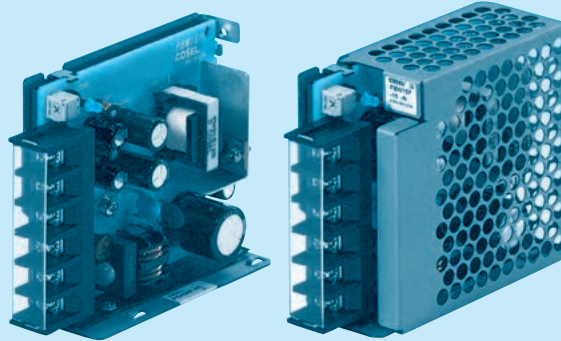
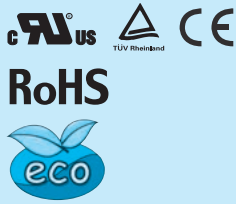

Example recommended EMI/EMC filter  
**NAC-06-472**



High voltage pulse noise type : NAP series  
 Low leakage current type : NAM series  
 \* A higher current rating EMI/EMC filter may be recommended in view of the other devices that could be connected in parallel with the power supply.

- ① Series name
- ② Dual output
- ③ Output wattage
- ④ Universal input
- ⑤ Output voltage
- ⑥ Optional \*10
- C : with Coating
- G : Low leakage current

E : Low leakage current and EMI class A

T : Vertical terminal block  
 J1 : VH (J.S.T) connector type  
 N : with Cover  
 Ni : with DIN rail  
 V : Output voltage setting potentiometer externally

Cover is optional

\*Make sure necessary tests will be carried out on your end equipment with the power supply installed in accordance with any required EMC/EMI regulations.

MODEL	PBW15F-12	PBW15F-15
MAX OUTPUT WATTAGE[W]	16.8	15.0
DC OUTPUT	VOLTAGE[V] *6	±12 ( +24 )
	CURRENT1[A]	0.7
	CURRENT2[A] *5	1.4
		1.0

## SPECIFICATIONS

	MODEL	PBW15F-12	PBW15F-15	
INPUT	VOLTAGE[V]	AC85 - 264 1 φ or DC110 - 370 (AC50 or DC70 Please refer to the instruction manual 1.1 Input voltage *8)		
	CURRENT[A]	ACIN 100V	0.40typ (CURRENT1)	
		ACIN 200V	0.20typ (CURRENT1)	
	FREQUENCY[Hz]	50/60 (47 - 440) or DC		
	EFFICIENCY[%]	ACIN 100V	74typ (CURRENT1)	78typ (CURRENT1)
		ACIN 200V	77typ (CURRENT1)	80typ (CURRENT1)
	INRUSH CURRENT[A]	ACIN 100V	15typ (CURRENT1) (At cold start)	
ACIN 200V		30typ (CURRENT1) (At cold start)		
LEAKAGE CURRENT[mA]	0.15/0.30max (ACIN 100V/240V 60Hz, Io=100%, According to IEC60950-1.DENAN)			
OUTPUT	VOLTAGE[V]	±12	±15 / ( +30V reference number )	
	CURRENT1[A]	0.7	0.5 / 0.5	
	CURRENT2[A] *5	1.4	1.0 / -	
	LINE REGULATION[mV] *9	60max	60max / 96max	
	LOAD REGULATION 1[mV] *9	600max	600max / 150max	
	LOAD REGULATION 2[mV] *9	750max	750max / -	
	RIPPLE[mVp-p]	0 to +50°C *1	120max / 240max	120max / 240max
		-10 - 0°C *1	160max / 320max	160max / 320max
	RIPPLE NOISE[mVp-p]	0 to +50°C *1	150max / 300max	150max / 300max
		-10 - 0°C *1	180max / 360max	180max / 360max
	TEMPERATURE REGULATION[mV]	0 to +50°C	120max	150max
		-10 to +50°C	150max	180max
	DRIFT[mV] *2	48max		60max
	START-UP TIME[ms]	200typ(ACIN 100V, Io=100%) * Start-up time is 700ms typ for less than 1minute of applying input again from turning off the input voltage.		
HOLD-UP TIME[ms]	20typ (ACIN 100V, Io=100%)			
OUTPUT VOLTAGE ADJUSTMENT RANGE[V]	9.60 - 13.2 (+V and -V are simultaneously adjusted)		13.2 - 16.5 (+V and -V are simultaneously adjusted)	
OUTPUT VOLTAGE SETTING[V]	11.5 - 12.5 (+V and -V CURRENT1)		14.4 - 15.6 (+V and -V CURRENT1)	
PROTECTION CIRCUIT AND OTHERS	OVERCURRENT PROTECTION	Works over 105% of rated current and recovers automatically		
	OVERVOLTAGE PROTECTION[V]	16.8 - 24.0	20.0 - 29.0	
	OPERATING INDICATION	LED (Green)		
	REMOTE ON/OFF	None		
ISOLATION	INPUT-OUTPUT	AC3.000V 1minute, Cutoff current = 10mA, DC500V 50MΩ min (At Room Temperature)		
	INPUT-FG	AC2.000V 1minute, Cutoff current = 10mA, DC500V 50MΩ min (At Room Temperature)		
	OUTPUT-FG	AC500V 1minute, Cutoff current = 25mA, DC500V 50MΩ min (At Room Temperature)		
ENVIRONMENT	OPERATING TEMP.,HUMID.AND ALTITUDE	-10 to +71°C (Refer to "Derating"), 20 - 90%RH (Non condensing) 3,000m (10,000feet) max		
	STORAGE TEMP.,HUMID.AND ALTITUDE	-20 to +75°C, 20 - 90%RH (Non condensing) 9,000m (30,000feet) max		
	VIBRATION	10 - 55Hz, 19.6m/s <sup>2</sup> (2G), 3minutes period, 60minutes each along X, Y and Z axis		
	IMPACT	196.1m/s <sup>2</sup> (20G), 11ms, once each X, Y and Z axis		
SAFETY AND NOISE REGULATIONS	AGENCY APPROVALS (At only AC input)	UL60950-1, C-UL(CSA60950-1), EN60950-1, EN50178 Complies with DEN-AN		
	CONDUCTED NOISE	Complies with FCC Part15 classB, VCCI-B, CISPR22-B, EN55011-B, EN55022-B		
	HARMONIC ATTENUATOR	Complies with IEC61000-3-2 (Not built-in to active filter *7) *12		
OTHERS	CASE SIZE/WEIGHT	31 X 78 X 85mm [1.22 X 3.07 X 3.35 inches] (without terminal block) (W X H X D) / 200g max (with cover : 235g max)		
	COOLING METHOD	Convection		

\*1 Measured by 20MHz oscilloscope or Ripple-Noise meter(equivalent to KEISOKU-GIKEN : RM101).  
 \*2 Drift is the change in DC output for an eight hour period after a half-hour warm-up at 25°C.  
 \*3 Figures for 0 to rated current 1.The current not measured side is fixed.  
 \*4 Figures for 0 to rated current 2.The current not measured side is fixed.  
 \*5 The sum of +power -power must be less than output power.  
 \*6 ±12, ±15 can be used as +24 and +30.  
 \*7 When two or more units are used, they may not comply with the harmonic attenuator. Please contact us for details.  
 \*8 Derating is required.  
 \*9 Figures to rated current 1.  
 \*10 Please contact us about safety approvals for the model with option.  
 \*11 Please contact us about dynamic load and input response.  
 \*12 Please contact us about class C.  
 \* Parallel operation with other model is not possible.  
 \* Derating is required when operated with cover.  
 \* A sound may occur from power supply at peak loading.

Block diagram

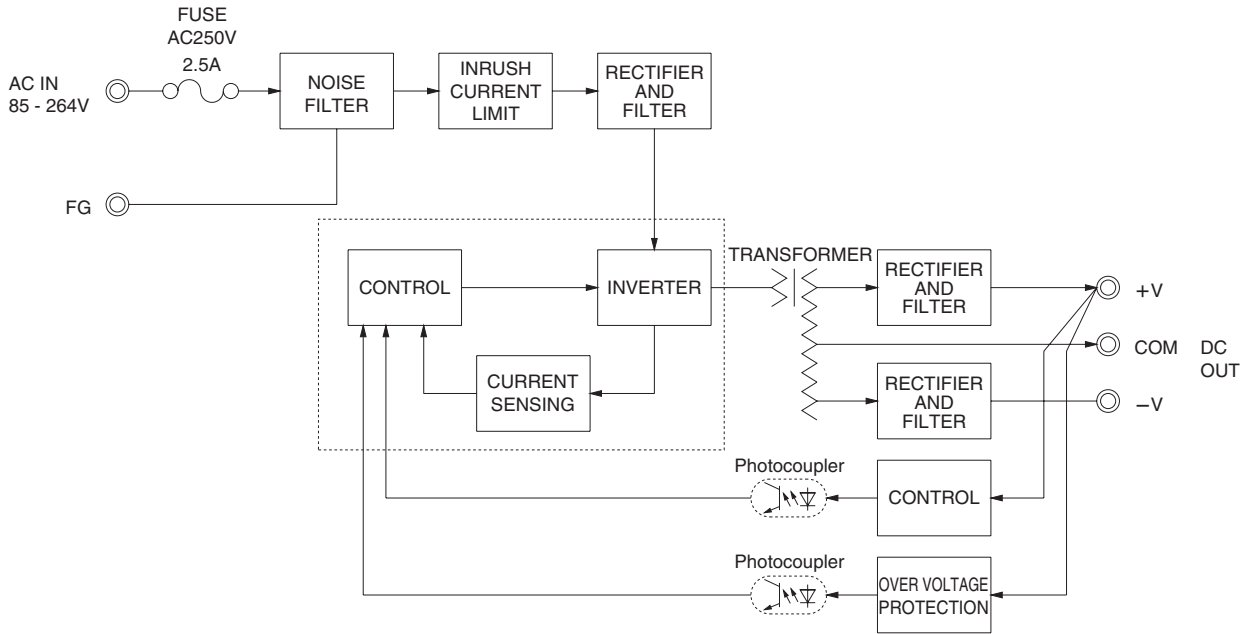

External view

※ External size of option T, J1, N1 and V is different from standard model and refer to 7 Option of instruction manual for details.

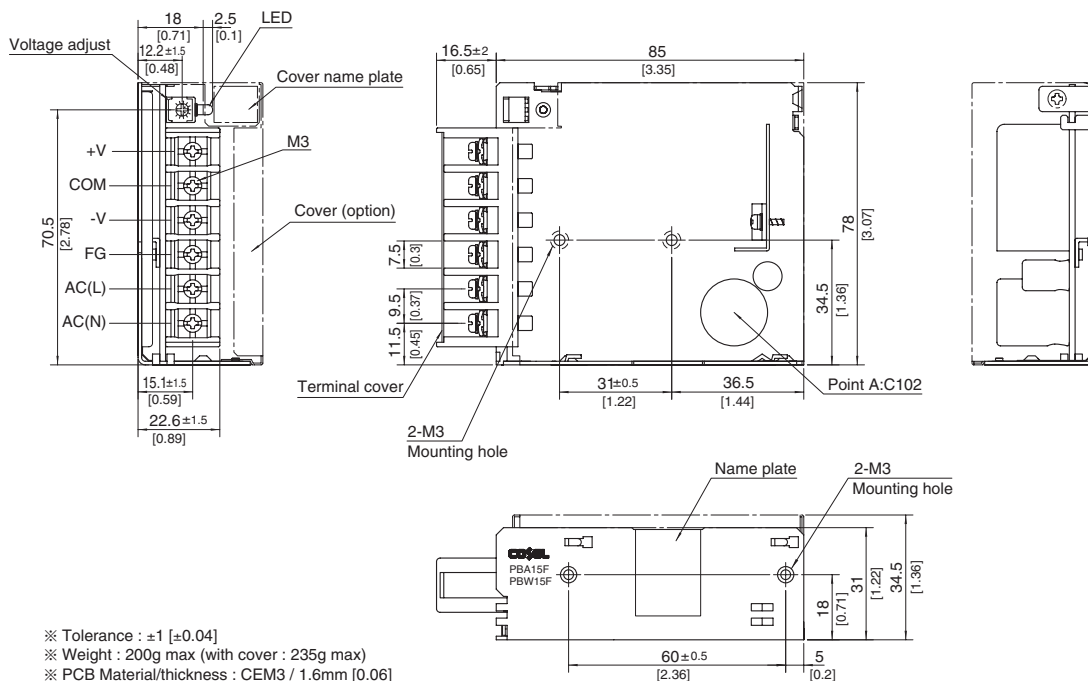

- ※ Tolerance : ±1 [±0.04]
- ※ Weight : 200g max (with cover : 235g max)
- ※ PCB Material/thickness : CEM3 / 1.6mm [0.06]
- ※ Chassis material : Electric galvanizing steel board
- ※ Dimensions in mm, [ ]= inches
- ※ Mounting torque : 0.6N • m(6.3kgf • cm)max
- ※ Screw tightening torque : M3 0.8N • m(8.5kgf • cm)max
- ※ Please connect safety ground to the unit in 2-M3 holes.

# PBW30F

PB W 30 F - □ - □  
 ① ② ③ ④ ⑤ ⑥

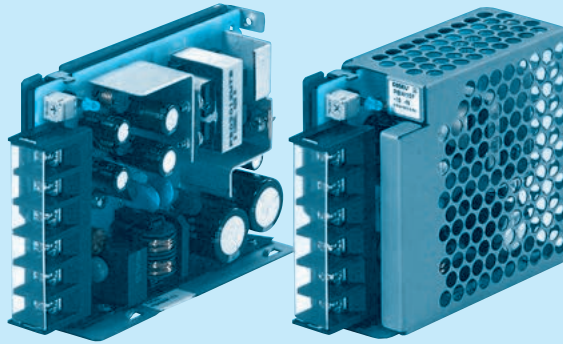
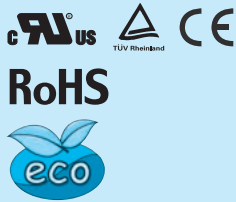

Example recommended EMI/EMC filter  
**NAC-06-472**



High voltage pulse noise type : NAP series  
 Low leakage current type : NAM series  
 \* A higher current rating EMI/EMC filter may be recommended in view of the other devices that could be connected in parallel with the power supply.

- ① Series name
- ② Dual output
- ③ Output wattage
- ④ Universal input
- ⑤ Output voltage
- ⑥ Optional \*10
- C : with Coating
- G : Low leakage current

E : Low leakage current and EMI class A

T : Vertical terminal block  
 J1 : V.H (J.S.T) connector type  
 N : with Cover  
 NI : with DIN rail  
 V : Output voltage setting potentiometer externally

Cover is optional

\*Make sure necessary tests will be carried out on your end equipment with the power supply installed in accordance with any required EMC/EMI regulations.

MODEL	PBW30F-5	PBW30F-12	PBW30F-15
MAX OUTPUT WATTAGE[W]	15	31.2	30.0
DC OUTPUT	VOLTAGE[V] *6	±5 (+10)	±12 (+24)
	CURRENT1[A]	1.5	1.3
	CURRENT2[A] *5	2.0	1.7

## SPECIFICATIONS

	MODEL	PBW30F-5	PBW30F-12	PBW30F-15	
INPUT	VOLTAGE[V]	AC85 - 264 1 φ or DC110 - 370 (AC50 or DC70 Please refer to the instruction manual 1.1 Input voltage *8)			
	CURRENT[A]	ACIN 100V	0.4typ (CURRENT1)	0.7typ (CURRENT1)	
		ACIN 200V	0.25typ (CURRENT1)	0.4typ (CURRENT1)	
	FREQUENCY[Hz]	50/60 (47 - 440) or DC			
	EFFICIENCY[%]	ACIN 100V	75typ (CURRENT1)	77typ (CURRENT1)	78typ (CURRENT1)
		ACIN 200V	75typ (CURRENT1)	81typ (CURRENT1)	79typ (CURRENT1)
INRUSH CURRENT[A]	ACIN 100V	15typ (CURRENT1) (At cold start)			
	ACIN 200V	30typ (CURRENT1) (At cold start)			
LEAKAGE CURRENT[mA]	0.30/0.65max (ACIN 100V/240V 60Hz, Io=100%, According to IEC60950-1.DENAN)				
OUTPUT	VOLTAGE[V]	±5 / (+10V reference number)	±12 / (+24V reference number)	±15 / (+30V reference number)	
	CURRENT1[A]	1.5 / 1.5	1.3 / 1.3	1.0 / 1.0	
	CURRENT2[A] *5	2.0 / -	1.7 / -	1.4 / -	
	LINE REGULATION[mV] *3 *11	20max / 36max	60max / 96max	60max / 96max	
	LOAD REGULATION 1[mV] *3 *11	250max / 100max	600max / 150max	600max / 150max	
	LOAD REGULATION 2[mV] *4 *11	500max / -	750max / -	750max / -	
	RIPPLE[mVp-p]	0 to +50°C *1	80max / 240max	120max / 240max	120max / 240max
		-10 - 0°C *1	140max / 320max	160max / 320max	160max / 320max
	RIPPLE NOISE[mVp-p]	0 to +50°C *1	120max / 300max	150max / 300max	150max / 300max
		-10 - 0°C *1	160max / 360max	180max / 360max	180max / 360max
	TEMPERATURE REGULATION[mV]	0 to +50°C	50max	120max	150max
	DRIFT[mV] *2	-10 to +50°C	60max	150max	180max
			20max	48max	60max
	START-UP TIME[ms]	200typ(ACIN 100V, Io=100%) * Start-up time is 700ms typ for less than 1minute of applying input again from turning off the input voltage.			
HOLD-UP TIME[ms]	20typ (ACIN 100V, Io=100%)				
OUTPUT VOLTAGE ADJUSTMENT RANGE[V]	4.99 - 6.00 (+V and -V are simultaneously adjusted)	9.60 - 13.2 (+V and -V are simultaneously adjusted)	13.2 - 16.5 (+V and -V are simultaneously adjusted)		
OUTPUT VOLTAGE SETTING[V]	4.99 - 5.30 (+V and -V CURRENT1)	11.5 - 12.5 (+V and -V CURRENT1)	14.4 - 15.6 (+V and -V CURRENT1)		
PROTECTION CIRCUIT AND OTHERS	OVERCURRENT PROTECTION	Works over 105% of rated current and recovers automatically			
	OVERVOLTAGE PROTECTION[V]	6.90 - 10.0	16.8 - 24.0	20.0 - 29.0	
	OPERATING INDICATION	LED (Green)			
	REMOTE ON/OFF	None			
ISOLATION	INPUT-OUTPUT	AC3,000V 1minute, Cutoff current = 10mA, DC500V 50MΩ min (At Room Temperature)			
	INPUT-FG	AC2,000V 1minute, Cutoff current = 10mA, DC500V 50MΩ min (At Room Temperature)			
	OUTPUT-FG	AC500V 1minute, Cutoff current = 25mA, DC500V 50MΩ min (At Room Temperature)			
ENVIRONMENT	OPERATING TEMP.,HUMID.AND ALTITUDE	-10 to +71°C (Refer to "Derating"), 20 - 90%RH (Non condensing) 3,000m (10,000feet) max			
	STORAGE TEMP.,HUMID.AND ALTITUDE	-20 to +75°C, 20 - 90%RH (Non condensing) 9,000m (30,000feet) max			
	VIBRATION	10 - 55Hz, 19.6m/s <sup>2</sup> (2G), 3minutes period, 60minutes each along X, Y and Z axis			
	IMPACT	196.1m/s <sup>2</sup> (20G), 11ms, once each X, Y and Z axis			
SAFETY AND NOISE REGULATIONS	AGENCY APPROVALS (At only AC input)	UL60950-1, C-UL(CSA60950-1), EN60950-1, EN50178 Complies with DEN-AN			
	CONDUCTED NOISE	Complies with FCC Part15 classB, VCCI-B, CISPR22-B, EN55011-B, EN55022-B			
	HARMONIC ATTENUATOR	Complies with IEC61000-3-2 (Not built-in to active filter *7) *12			
OTHERS	CASE SIZE/WEIGHT	31 X 78 X 103mm [1.22 X 3.07 X 4.06 inches] (without terminal block) (W X H X D) / 270g max (with cover : 310g max)			
	COOLING METHOD	Convection			

\*1 Measured by 20MHz oscilloscope or Ripple-Noise meter(equivalent to KEISOKU-GIKEN : RM101).  
 \*2 Drift is the change in DC output for an eight hour period after a half-hour warm-up at 25°C.  
 \*3 Figures for 0 to rated current 1.The current not measured side is fixed.  
 \*4 Figures for 0 to rated current 2.The current not measured side is fixed.  
 \*5 The sum of +power -power must be less than output power.  
 \*6 ±5, ±12, ±15 can be used as +10, +24 and +30.  
 \*7 When two or more units are used, they may not comply with the harmonic attenuator. Please contact us for details.  
 \*8 Derating is required.  
 \*9 Figures to rated current 1.  
 \*10 Please contact us about safety approvals for the model with option.  
 \*11 Please contact us about dynamic load and input response.  
 \*12 Please contact us about class C.  
 \* Parallel operation with other model is not possible.  
 \* Derating is required when operated with cover.  
 \* A sound may occur from power supply at peak loading.

Block diagram

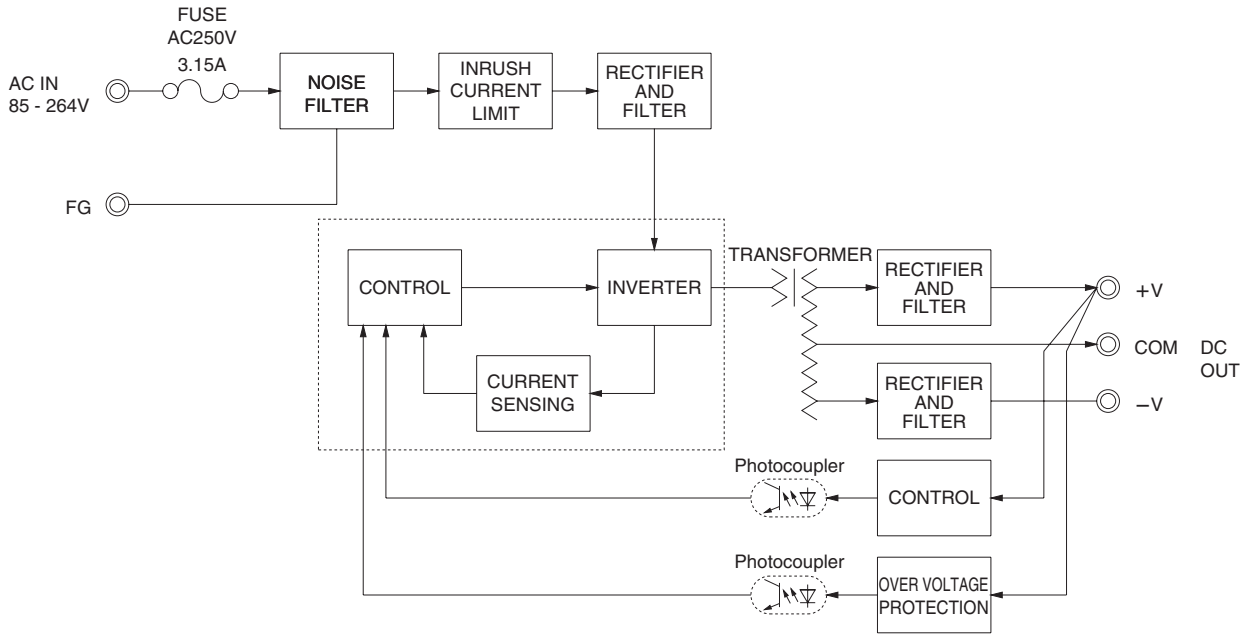

External view

※ External size of option T, J1, N1 and V is different from standard model and refer to 7 Option of instruction manual for details.

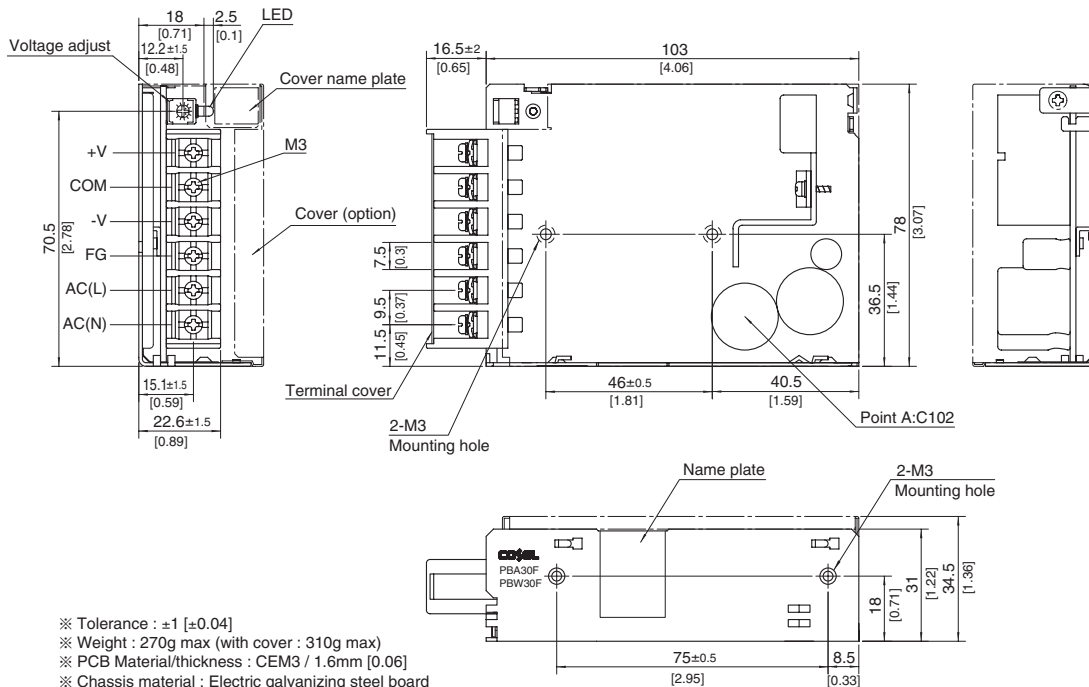

- ※ Tolerance :  $\pm 1$  [±0.04]
- ※ Weight : 270g max (with cover : 310g max)
- ※ PCB Material/thickness : CEM3 / 1.6mm [0.06]
- ※ Chassis material : Electric galvanizing steel board
- ※ Dimensions in mm, [ ] = inches
- ※ Mounting torque : 0.6N • m (6.3kgf • cm) max
- ※ Screw tightening torque : M3 0.8N • m (8.5kgf • cm) max
- ※ Please connect safety ground to the unit in 2-M3 holes.

# PBW50F

PB W 50 F -□ -□  
 ① ② ③ ④ ⑤ ⑥

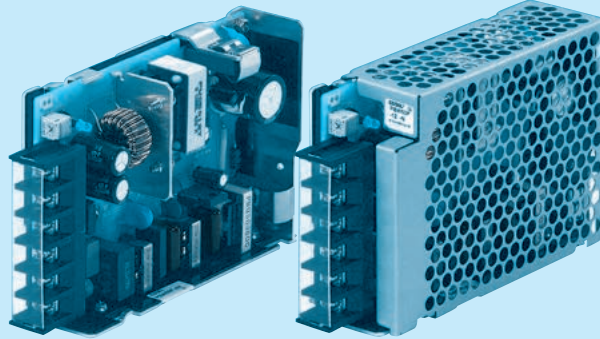
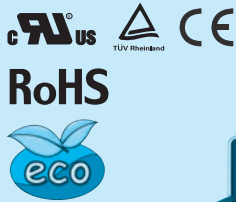

Example recommended EMI/EMC filter  
**NAC-06-472**



High voltage pulse noise type : NAP series  
 Low leakage current type : NAM series  
 \* A higher current rating EMI/EMC filter may be recommended in view of the other devices that could be connected in parallel with the power supply.

- ① Series name
- ② Dual output
- ③ Output wattage
- ④ Universal input
- ⑤ Output voltage
- ⑥ Optional \*9
- C : with Coating
- G : Low leakage current (0.15mA max / ACIN 240V)
- E : Low leakage current and EMI class A (0.5mA max / ACIN 240V)
- T : Vertical terminal block
- J1 : VH (J.S.T.) connector type
- R : with Remote ON/OFF
- N : with Cover
- N1 : with DIN rail
- V : Output voltage setting potentiometer externaly

Cover is optional

\*Make sure necessary tests will be carried out on your end equipment with the power supply installed in accordance with any required EMC/EMI regulations.

MODEL	PBW50F-5	PBW50F-12	PBW50F-15
MAX OUTPUT WATTAGE[W]	30	50.4	51
VOLTAGE[V]	±5 (+10)	±12 (+24)	±15 (+30)
DC OUTPUT	CURRENT1[A]	2.1	1.7
	CURRENT2[A]	2.7	2.4

## SPECIFICATIONS

	MODEL	PBW50F-5	PBW50F-12	PBW50F-15	
INPUT	VOLTAGE[V]	AC85 - 264 1 φ or DC120 - 370 (AC50 or DC70 Please refer to the instruction manual 1.1 Input voltage *3)			
	CURRENT[A]	ACIN 100V	0.45typ (CURRENT1)	0.70typ (CURRENT1)	
		ACIN 200V	0.30typ (CURRENT1)	0.40typ (CURRENT1)	
	FREQUENCY[Hz]	50/60 (47 - 63)			
	EFFICIENCY[%]	ACIN 100V	76typ (CURRENT1)	81typ (CURRENT1)	81typ (CURRENT1)
		ACIN 200V	77typ (CURRENT1)	83typ (CURRENT1)	83typ (CURRENT1)
	POWER FACTOR(lo=100%)	ACIN 100V	0.98typ	0.99typ	
ACIN 200V		0.87typ	0.93typ		
INRUSH CURRENT[A]	ACIN 100V	15typ (CURRENT1) (At cold start)			
	ACIN 200V	30typ (CURRENT1) (At cold start)			
LEAKAGE CURRENT[mA]	0.40/0.75max (ACIN 100V/240V 60Hz, lo=100%, According to IEC60950-1.DENAN)				
OUTPUT	VOLTAGE[V]	±5 / (+10V reference number)	±12 / (+24V reference number)	±15 / (+30V reference number)	
	CURRENT1[A]	3.0 / 3.0	2.1 / 2.1	1.7 / 1.7	
	CURRENT2[A]	4.0 / -	2.7 / -	2.4 / -	
	LINE REGULATION[mV]	20max / 36max	48max / 96max	60max / 96max	
	LOAD REGULATION 1[mV]	250max / 100max	600max / 150max	600max / 150max	
	LOAD REGULATION 2[mV]	500max / -	750max / -	750max / -	
	RIPPLE[mVp-p]	0 to +50°C	80max / 240max	120max / 240max	120max / 240max
		-10 - 0°C	140max / 320max	160max / 320max	160max / 320max
	RIPPLE NOISE[mVp-p]	0 to +50°C	120max / 300max	150max / 300max	150max / 300max
		-10 - 0°C	160max / 360max	180max / 360max	180max / 360max
	TEMPERATURE REGULATION[mV]	0 to +50°C	50max	120max	150max
		-10 to +50°C	60max	150max	180max
	DRIFT[mV]	20max	48max	60max	
	START-UP TIME[ms]	350typ(ACIN 100V, lo=100%)			
HOLD-UP TIME[ms]	20typ (ACIN 100V, lo=100%)				
OUTPUT VOLTAGE ADJUSTMENT RANGE[V]	4.99 - 6.00 (+V and -V are simultaneously adjusted)	9.60 - 13.2 (+V and -V are simultaneously adjusted)	13.2 - 16.5 (+V and -V are simultaneously adjusted)		
OUTPUT VOLTAGE SETTING[V]	4.99 - 5.30 (+V and -V CURRENT1)	11.5 - 12.5 (+V and -V CURRENT1)	14.4 - 15.6 (+V and -V CURRENT1)		
PROTECTION CIRCUIT AND OTHERS	OVERCURRENT PROTECTION	Works over 105% of rated current and recovers automatically			
	OVERVOLTAGE PROTECTION[V]	6.90 - 10.0	16.8 - 24.0	20.0 - 29.0	
	OPERATING INDICATION	LED (Green)			
	REMOTE ON/OFF	Optional (Required external power source)			
ISOLATION	INPUT-OUTPUT - RC	*7 AC3.000V 1minute, Cutoff current = 10mA, DC500V 50MΩ min (At Room Temperature)			
	INPUT-FG	AC2.000V 1minute, Cutoff current = 10mA, DC500V 50MΩ min (At Room Temperature)			
	OUTPUT - RC-FG	*7 AC500V 1minute, Cutoff current = 100mA, DC500V 50MΩ min (At Room Temperature)			
ENVIRONMENT	OPERATING TEMP.,HUMID.AND ALTITUDE	-10 to +71°C (Refer to "Derating"), 20 - 90%RH (Non condensing) 3,000m (10,000feet) max			
	STORAGE TEMP.,HUMID.AND ALTITUDE	-20 to +75°C, 20 - 90%RH (Non condensing) 9,000m (30,000feet) max			
	VIBRATION	10 - 55Hz, 19.6m/s <sup>2</sup> (2G), 3minutes period, 60minutes each along X, Y and Z axis			
	IMPACT	196.1m/s <sup>2</sup> (20G), 11ms, once each X, Y and Z axis			
SAFETY AND NOISE REGULATIONS	AGENCY APPROVALS (At only AC input)	UL60950-1, C-UL(CSA60950-1), EN60950-1, EN50178 Complies with DEN-AN			
	CONDUCTED NOISE	Complies with FCC Part15 classB, VCCI-B, CISPR22-B, EN55011-B, EN55022-B			
	HARMONIC ATTENUATOR	Complies with IEC61000-3-2 *10			
OTHERS	CASE SIZE/WEIGHT	31 x 82 x 120mm [1.22 x 3.23 x 4.72 inches] (without terminal block) (W x H x D) / 280g max (with cover : 325g max)			
	COOLING METHOD	Convection			

\*1 Measured by 20MHz oscilloscope or Ripple-Noise meter(equivalent to KEISOKU-GIKEN : RM101).  
 \*2 Drift is the change in DC output for an eight hour period after a half-hour warm-up at 25°C.  
 \*3 Derating is required.  
 \*4 Figures for 0 to rated current 1.The current not measured side is fixed.  
 \*5 Figures for 0 to rated current 2.The current not measured side is fixed.  
 \*6 The sum of +power -power must be less than output power.  
 \*7 RC is applied to remote ON/OFF option. RC is isolated with input/output and FG.  
 \*8 ±5, ±12, ±15 can be used as +10,+24 and +30.  
 \*9 Please contact us about safety approvals for the model with option.  
 \*10 Please contact us about class C.  
 \* Parallel operation with other model is not possible.  
 \* Derating is required when operated with cover.  
 \* A sound may occur from power supply at peak loading.



Block diagram

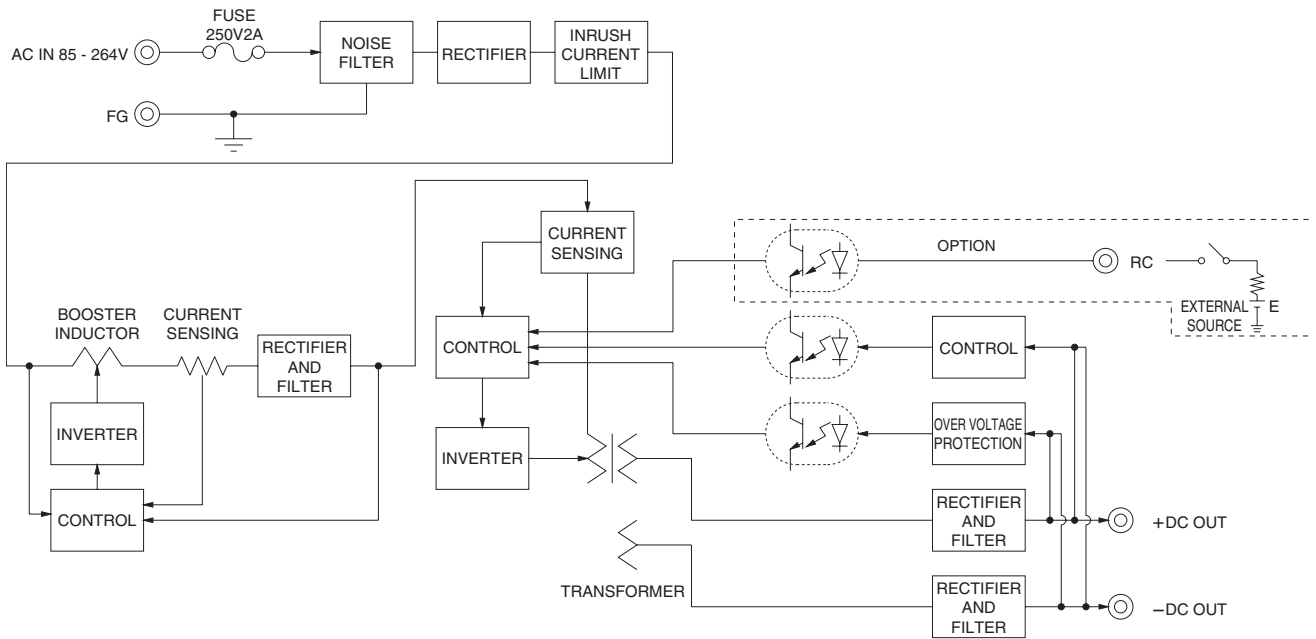

External view

※ External size of option T,J1,R,N1 and V is different from standard model and refer to 7 Option of instruction manual for details.

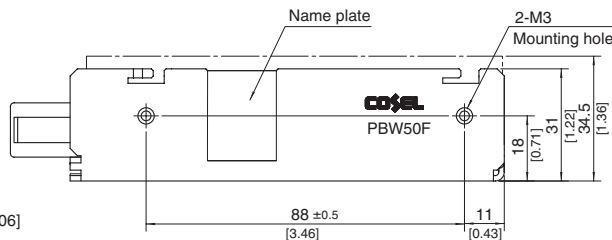
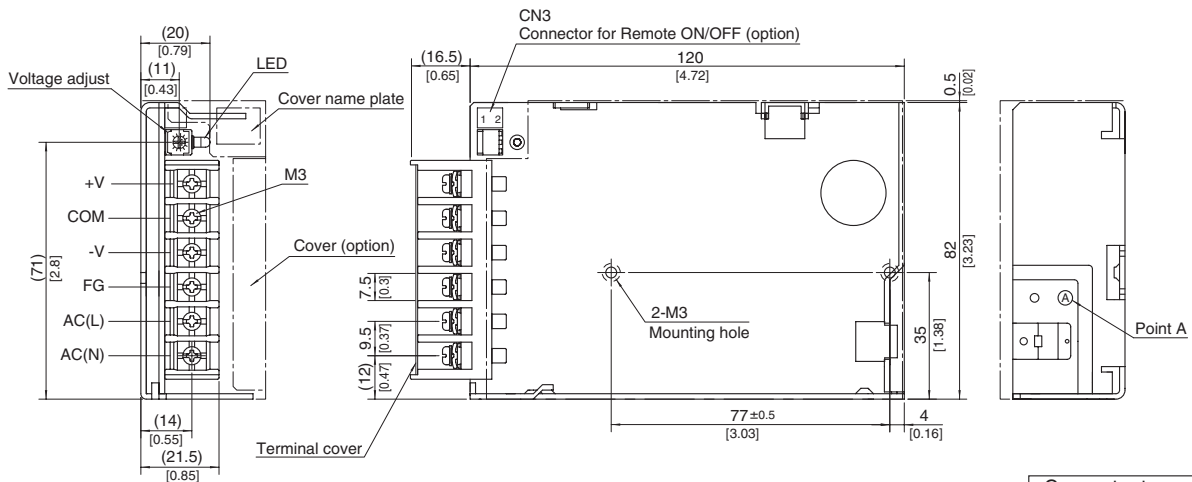

Connector type	
CN3 Option (Mfr : J.S.T.)	
Pin No.	Contents
1	RC(+)
2	RC(-)

Barrier strip type  
 Model B2B-XH-A  
 Mating Connector (Terminal)  
 XHP-2  
 (BXH-001T-P0.6  
 or SXH-001T-P0.6)

- ※ Tolerance : ±1 [±0.04]
- ※ Weight : 280g max (with cover : 325g max)
- ※ PCB Material/thickness : CEM3 / 1.6mm [0.06]
- ※ Chassis material : Aluminum
- ※ Dimensions in mm, [ ] = inches
- ※ Mounting torque : 0.49N · m (5kgf · cm) max
- ※ Screw tightening torque : M3 0.8N · m (8.5kgf · cm) max
- ※ Please connect safety ground to the unit in 2-M3 holes.



## Terminal Blocks

\*The following information covers PBA300F - 1500F. Please see External View for PBA10F - 150F and PBW15F - 50F.

### ● PBA300F

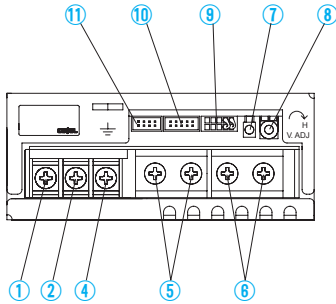

### ● PBA600F

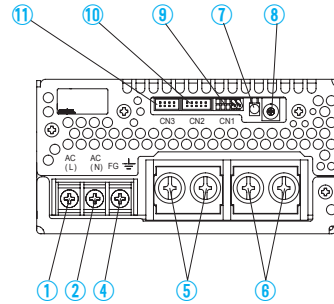

### ● PBA1000F

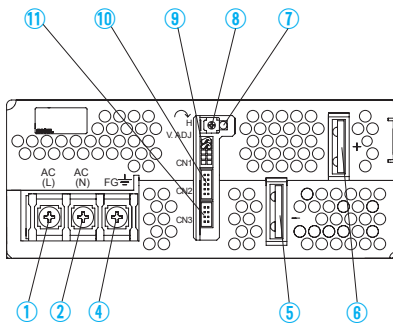

### ● PBA1500F

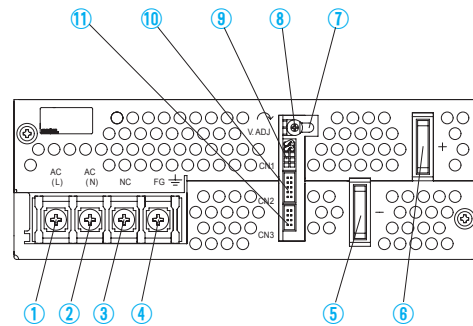

### ● PBA1500T

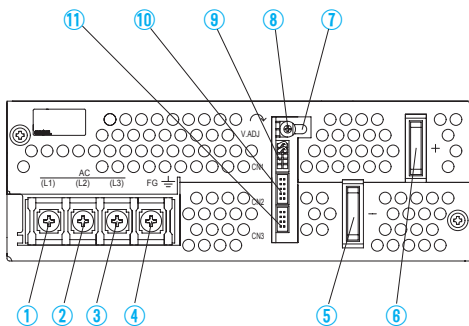

\*PBA300F - 1500F

- ①AC (L) } Input Terminals AC85 - 264V  $\phi$  47 - 63Hz
- ②AC (N) } (M4)
- ③NC
- ④Frame ground (M4  $\perp$ )
- ⑤-Output
- ⑥+Output
- ⑦LED
- ⑧Output voltage adjustable potentiometer
- ⑨CN1 } Connectors
- ⑩CN2 }
- ⑪CN3 }

\*Please see Optional Parts for dedicated harnesses.

\*PBA1500T

- ①AC (L1)
- ②AC (L2)
- ③AC (L3)
- ④Frame ground (M4  $\perp$ )
- ⑤-Output
- ⑥+Output
- ⑦LED
- ⑧Output voltage adjustable potentiometer
- ⑨CN1 } Connectors
- ⑩CN2 }
- ⑪CN3 }

Terminal Blocks

● PBA300F, 600F Pin Configuration

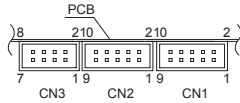

● PBA1000F, 1500F Pin Configuration

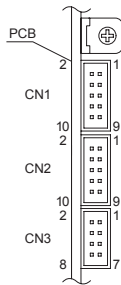

Pin Configuration and Functions of CN1 and CN2

Pin No.	Function
1	+M : Self sensing terminal. (Do not wire for external connection.)
2	+S : +Sensing
3	-M : Self sensing terminal. (Do not wire for external connection.)
4	-S : -Sensing
5	VB : Voltage balance
6	CB : Current balance
7	TRM : Adjustment of output voltage
8	-S : -Sensing
9	RC2 : Remote ON/OFF
10	RCG : Remote ON/OFF (GND)

Pin Configuration and Functions of CN3

Pin No.	Function
1	-S : -Sensing
2	-S : -Sensing
3	AUX : Auxiliary output (12V 0.1A)
4	RC1 : Remote ON/OFF
5	AUXG : Auxiliary output (GND)
6	N.C. : No connection
7	PG : Alarm
8	PGG : Alarm (GND)

\*Common signs among CN1, CN2 and CN3 such as -S represent the same potential.

Matching connectors and terminals on CN1, CN2 and CN3

Connector	Housing	Terminal	Mfr.
CN1 CN2	S10B-PHDSS PHDR-10VS	Reel : SPHD-002T-P0.5 Loose : BPHD-001T-P0.5	J.S.T.
CN3	S8B-PHDSS PHDR-08VS		

Assembling and Installation Method

Installation Method

■ Do not insert a screw more than 6mm from the outside of a power supply to keep enough insulation distance between the screw and internal components.

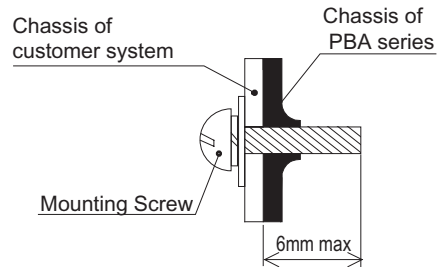

● PBA10F, PBA15F, PBW15F, PBA30F, PBW30F, PBA50F, PBW50F, PBA75F, PBA100F and PBA150F

- If you use two or more power supplies side by side, please keep a sufficient distance between them to allow enough air ventilation.
- Ambient temperature around each power supply should not exceed the temperature range shown in "derating".

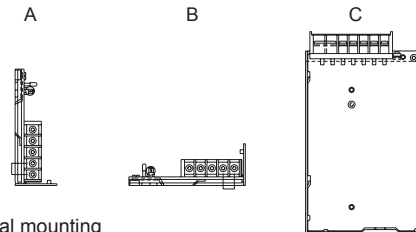

Normal mounting

● PBA300F, PBA600F, PBA1000F, PBA1500F and PBA1500T

- The power supplies have a built-in forced cooling fan. Do not block ventilation at the suction side (terminal block side) and its opposite side (fan installation side). If you need to secure a power supply by screws, securely fix it, taking into consideration of its weight. You can install it in any direction.
- If you use a power supply in a dusty environment, it can give a cause for a failure. Please consider taking such countermeasures as installing an air filter near the suction area of the system to prevent a failure.
- In PBA300F, PBA1500F and PBA1500T, ventilation holes are located on the mounting side. If you would like to install the unit by using that side, please contact us for details.

Derating

● PBA10F, PBA15F, PBW15F, PBA30F, PBW30F Input voltage Derating Curve

● PBA1500F Input voltage Derating Curve

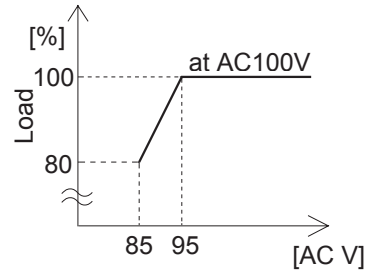
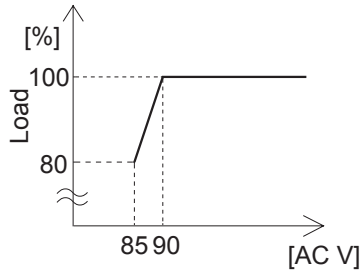

● PBA10F, PBA15F, PBW15F, PBA30F, PBW30F, PBA50F, PBW50F, PBA75F, PBA100F, PBA150F Ambient temperature derating curve

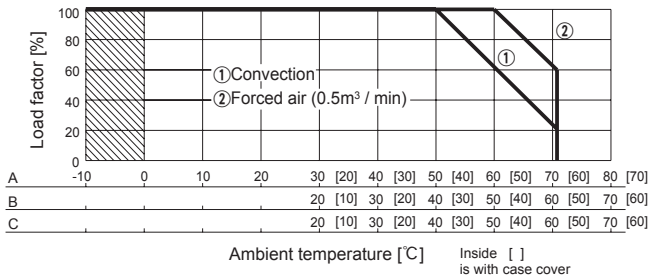

- In the hatched area, the specification of Ripple, Ripple Noise is different from other area.
- The ambient temperature should be measured 5 to 10 cm away from the power supply so that it won't be influenced by the heat from the power supply. Please consult us for more details.
- Make sure the temperature at point A is less than the temperatures shown in Instruction Manual 4.

● PBA300F, PBA600F, PBA1000F, PBA1500F, PBA1500T Ambient temperature derating curve

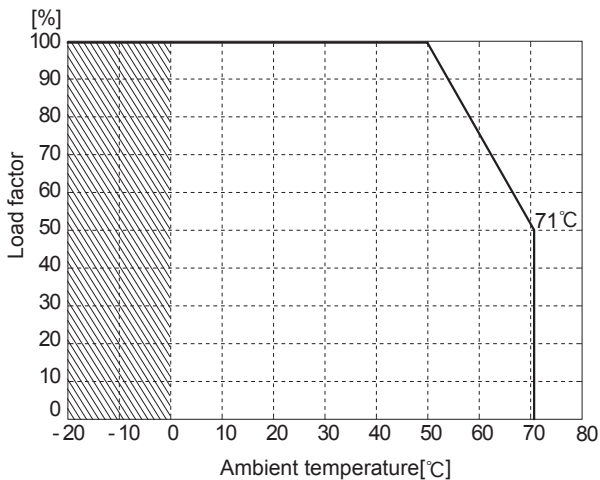

- In the hatched area, the specification of Ripple, Ripple Noise is different from other area.
- Derating curve depending on an ambient temperature (temperature of air sucked in for a cooling purpose) is shown above.

## Instruction Manual

◆ It is necessary to read the “Instruction Manual” and “Before using our product” before you use our product.

Instruction Manual <https://en.cosel.co.jp/product/powersupply/PBA/>  
 Instruction Manual <https://en.cosel.co.jp/product/powersupply/PBW/>  
 Before using our product <https://en.cosel.co.jp/technical/caution/index.html>



## Basic Characteristics Data

Model	Circuit method	Switching frequency [kHz]	Input current [A]	Rated input fuse	Inrush current protection circuit	PCB/Pattern			Series/Parallel operation availability	
						Material	Single sided	Double sided	Series operation	Parallel operation
PBA10F	Flyback converter	100	0.3	250V 2.5A	LF	CEM-3	Yes		Yes	*1
PBA15F	Flyback converter	100	0.4		Thermistor	CEM-3	Yes		Yes	*1
PBA30F	Flyback converter	100	0.7		Thermistor	CEM-3	Yes		Yes	*1
PBA50F	Active filter	60 - 550	0.7	250V 2A	Thermistor	CEM-3	Yes		Yes	*1
	Forward converter	130								
PBA75F	Active filter	60 - 550	1.0	250V 3.15A	Thermistor	CEM-3	Yes		Yes	*1
	Forward converter	120								
PBA100F	Active filter	60 - 550	1.3	250V 3.15A	Thermistor	CEM-3	Yes		Yes	*1
	Forward converter	120								
PBA150F	Active filter	60 - 550	2.0	250V 4A	Thermistor	CEM-3	Yes		Yes	*1
	Forward converter	120								
PBA300F	Active filter	230	4.1	250V 10A	SCR	FR-4		Yes	Yes	Yes
	Forward converter	330								
PBA600F	Active filter	130	8.2	250V 15A	SCR	FR-4		Yes	Yes	Yes
	Forward converter	330								
PBA1000F	Active filter	130	13	250V 30A	SCR	FR-4		Yes	Yes	Yes
	Forward converter	280								
PBA1500F	Active filter	130	19	250V 30A	SCR	FR-4		Yes	Yes	Yes
	Forward converter	200								
PBA1500T	Active filter	130	6	250V 16A	SCR	FR-4		Yes	Yes	Yes
	Forward converter	200								
PBW15F	Flyback converter	100	0.4	250V 2.5A	Thermistor	CEM-3	Yes		Yes	*1
PBW30F	Flyback converter	100	0.7	250V 3.15A	Thermistor	CEM-3	Yes		Yes	*1
PBW50F	Active filter	60 - 550	0.7	250V 2A	Thermistor	CEM-3	Yes		Yes	*1
	Forward converter	130								

\*1 Refer to Series/Parallel Operation of Instruction Manual.

\* The value of input current is at ACIN 100V and rated load, ACIN 200V 3 φ and rated load in PBA1500T.